

KUBOTA

- U.S.A. : **KUBOTA ENGINE AMERICA CORPORATION**
505 Schelter Road, Lincolnshire, Illinois 60069 U.S.A.
Telephone : (847)955-2500
- Canada : **KUBOTA CANADA LTD.**
5900 14th Avenue, Markham, Ontario, L3S 4K4, Canada
Telephone : (905)294-7477
- France : **KUBOTA EUROPE S.A.S**
19-25, Rue Jules Verceyruysse, Z.I. BP88, 95101 Argenteuil Cedex, France
Telephone : (33)1-3426-3434
- Italy : **KUBOTA EUROPE S.A.S Italy Branch**
Via Grandi, 29 20068 Peschiera Borrome (MI) Italy
Telephone : (39)02-51650377
- Germany : **KUBOTA (DEUTSCHLAND) GmbH**
Senefeldler Str. 3-5 63110 Rodgau /Nieder-Roden, Germany
Telephone : (49)6106-873-0
- U.K. : **KUBOTA (U.K.) LTD.**
Dormer Road, Thame, Oxfordshire, OX9 3UN, U.K.
Telephone : (44)1844-214500
- Australia : **KUBOTA AUSTRALIA PTY LTD.**
25-29 Permas Way, Truganina, VIC 3029, Australia
Telephone : (61)-3-9394-4400
- Malaysia : **KUBOTA MALAYSIA SDN. BHD.**
No.3 Jalan Sepadu 25/123 Taman Perindustrian Axis,
Seksyen 25, 40400 Shah Alam, Selangor Darul Ehsan Malaysia
Telephone : (60)3-736-1388
- Philippines: **KUBOTA PHILIPPINES, INC.**
232 Quirino Highway, Baesa, Quezon City 1106, Philippines
Telephone : (63)2-422-3500
- Indonesia : **P.T. KUBOTA INDONESIA**
Taman Industri Bukit Semarang Baru(BSB) Blok D.1 Kav.8, Kel. Jatibarang-
Kec.Mijen, Semarang, Indonesia
Telephone : (62)-24-7472849
- Japan : **KUBOTA Corporation**
Engine Export Dept.
2-47, Shikitsuhashi 1-chome, Naniwa-ku, Osaka, Japan 556-8601
Telephone : (81)6-6648-2155 Fax : (81)6-6648-3521

Code No. 1J500-8915-9

V
2
6
0
7
-
C
R
I
T
I
E
4
·
V
3
8
0
0
-
C
R
I
T
I
E
4
·
V
2
6
0
7
-
C
R
I
T
I
E
4
·
V
3
3
0
7
-
C
R
I
T
I
E
4
·
V
2
4
0
3
-
C
R
I
T
I
E
4
·
V
3
8
0
0
-
C
R
I
T
I
E
4
·
V
2
4
0
3
-
C
R
I
T
I
E
4
·
V
3
8
0
0
-
C
R
I
T
I
E
4
·
V
2
6
0
7
-
C
R
I
T
I
E
4

OPERATOR'S MANUAL KUBOTA DIESEL ENGINE

MANUEL DE L'OPERATEUR MOTEUR DIESEL DE KUBOTA

BEDIENUNGSANLEITUNG KUBOTA DIESEL MOTOR

MANUALE DELL'OPERATORE KUBOTA MOTORE DIESEL

MANUAL DE INSTRUCCIONES KUBOTA MOTOR DIESEL

D1803-CR-E4
D1803-CR-TE4
V2403-CR-E4
V2403-CR-TE4

V2607-CR-E4
V2607-CR-TE4
V3307-CR-TE4

V3800-CR-TE4
V3800-CR-TIE4

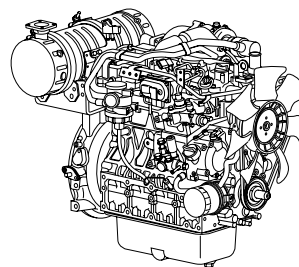

1ABACCJAP0010

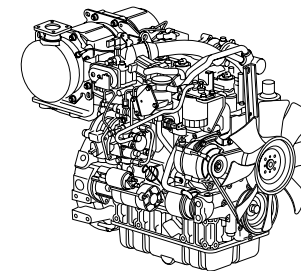

1ABAHABAP0010

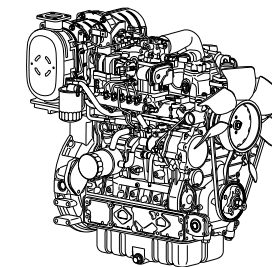

1ABADBMAP0010

READ AND SAVE THIS BOOK
MANUEL A LIRE ET A CONSERVER
DIESE ANLEITUNG BITTE SORGFÄLTIG DURCHLESEN
UND GRIFFBEREIT AUFBEWAHREN
LEGGETE E CONSERVATE QUESTO MANUALE
LEAN Y CONSERVEN ESTE MANUAL

California Proposition 65

⚠ WARNING ⚠

Engine exhaust, some of its constituents, certain vehicle components and fluids, contain or emit chemicals known to the State of California to cause cancer and birth defects or other reproductive harm.

D1803-CR-E4/D1803-CR-TE4
V2403-CR-E4/V2403-CR-TE4
V2607-CR-E4/V2607-CR-TE4/V3307-CR-TE4
V3800-CR-TE4/V3800-CR-TIE4
AY. A. 10-39. 20. K

OPERATOR'S MANUAL

KUBOTA DIESEL ENGINE

MODELS

D1803-CR-E4

D1803-CR-TE4

V2403-CR-E4

V2403-CR-TE4

V2607-CR-E4

V2607-CR-TE4

V3307-CR-TE4

V3800-CR-TE4

V3800-CR-TIE4

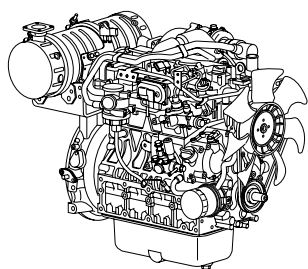

1ABACCJAP0010

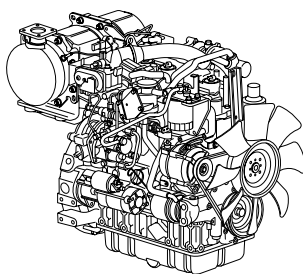

1ABAHABAP0010

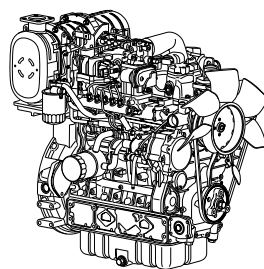

1ABADBMAP0010

READ AND SAVE THIS BOOK

Kubota

FOREWORD

You are now the proud owner of a KUBOTA Engine. This engine is a product of KUBOTA quality engineering and manufacturing. It is made of fine materials and under a rigid quality control system. It will give you long, satisfactory service. To obtain the best use of your engine, please read this manual carefully. It will help you become familiar with the operation of the engine and contains many helpful hints about engine maintenance. It is KUBOTA's policy to utilize as quickly as possible every advance in our research. The immediate use of new techniques in the manufacture of products may cause some small parts of this manual to be outdated. KUBOTA distributors and dealers will have the most up-to-date information. Please do not hesitate to consult with them.

This Operator's Manual should be considered a permanent part of the engine and should remain with the engine when it is resold.



SAFETY FIRST

This symbol, the industry's "Safety Alert Symbol", is used throughout this manual and on labels on the machine itself to warn of the possibility of personal injury. Read these instructions carefully. It is essential that you read the instructions and safety regulations before you attempt to assemble or use this unit.



DANGER : Indicates an imminently hazardous situation which, if not avoided, will result in death or serious injury.



WARNING : Indicates a potentially hazardous situation which, if not avoided, could result in death or serious injury.



CAUTION : Indicates a potentially hazardous situation which, if not avoided, could result in minor or moderate injury.

IMPORTANT : Indicates that equipment or property damage could result if instructions are not followed.

NOTE : Gives helpful information.

CONTENTS

▲SAFE OPERATION	1
SERVICING OF THE ENGINE	1
NAMES OF PARTS	2
PRE-OPERATION CHECK	5
BREAK-IN	5
DAILY CHECK	5
OPERATING THE ENGINE	6
STARTING THE ENGINE (NORMAL)	6
COLD WEATHER STARTING	7
STOPPING THE ENGINE	7
CHECKS DURING OPERATION	8
Radiator cooling water (Coolant)	8
Oil pressure lamp	8
Charge lamp	8
Fuel	8
Color of exhaust	8
Immediately stop the engine if	8
DIESEL PARTICULATE FILTER (DPF)	9
AIR FLOW SENSOR	9
Air cleaner-mounted type	9
Inlet hose pipe-mounted type	9
PRECAUTIONS ON GENERATOR-EQUIPPED ENGINE	9
MAINTENANCE	10
SERVICE INTERVALS	11
Water separator	13
DAILY CHECKS	13
Checking of engine oil level	13
Checking of fuel level	15
Checking of coolant level	15
Anti-freeze	17
Checking of fan belt	18
REGULAR CHECKS AND MAINTENANCE WORK	19
EVERY 50 SERVICE HOURS	19
Checking of fuel pipes and clamp bands	19
Draining of water separator (Type 1)	19
EVERY 250 SERVICE HOURS	20
Checking of radiator hoses and clamp bands	20
Precaution at overheating	20
Cleaning of air cleaner element	20
Adjustment of fan belt tension	21
Checking of intake air line	21
EVERY 400 SERVICE HOURS	22
Changing of engine oil	22
Replacement of oil filter cartridge	22
EVERY 500 SERVICE HOURS	23
Changing of engine oil	23
Replacement of oil filter cartridge	23

Replacement of fuel filter cartridge	24
Cleaning of water separator (Type 1)	24
Removal of sediment in fuel tank	24
Cleaning of water jacket (radiator interior)	24
Replacement of fan belt	24
EVERY 500 SERVICE HOURS OR 1 YEAR	24
Replacement of water separator filter (Type 2)	24
EVERY 1000 SERVICE HOURS	24
Checking of valve clearance	24
EVERY 1500 SERVICE HOURS	24
Checking of injector tip	24
Checking of EGR cooler	24
Changing of oil separator element	25
Checking of PCV valve (Positive Crankcase Ventilation valve)	25
EVERY 3000 SERVICE HOURS	26
Checking of turbo-charger	26
Cleaning of DPF	26
Checking of EGR System	26
ANNUAL SERVICING	26
Replacement of air cleaner element	26
Checking of DPF related piping	26
Checking of EGR piping	26
Checking of intake air line	26
Checking of exhaust manifold for cracks or gas leak and for looseness or damage	26
BIENNIAL SERVICING	26
Replacement of oil separator related rubber piping	26
Replacement of DPF related rubber piping	26
Replacement of intake air line and suction air pressure takeout rubber piping	26
Replacement of boost sensor pressure rubber piping	26
Replacement of EGR cooler rubber piping	26
Replacement of water rubber piping	26
Replacement of lubricant rubber piping	26
Changing of radiator coolant (L.L.C.)	27
Remedies for quick decrease of coolant	27
Replacement of radiator hoses and clamp bands	27
Replacement of fuel pipes and clamp bands	27
Replacement of intake air line	27
Replacement of fan belt	27
SERVICE AS REQUIRED	27
Draining of water separator (Type 2)	27
CARRIAGE AND STORAGE	28
CARRIAGE	28
STORAGE	28
TROUBLESHOOTING	29
SPECIFICATIONS	31



SAFE OPERATION

Careful operation is your best assurance against an accident. Read and understand this section carefully before operating the engine. All operators, no matter how much experience they may have, should read this and other related manuals before operating the engine or any equipment attached to it. It is the owner's obligation to provide all operators with this information and instruct them on safe operation.

Be sure to observe the following for safe operation.

1. OBSERVE SAFETY INSTRUCTIONS

- Read and understand carefully this "OPERATOR'S MANUAL" and "LABELS ON THE ENGINE" before attempting to start and operate the engine.
- Learn how to operate and work safely. Know your equipment and its limitations. Always keep the engine in good condition.
- Before allowing other people to use your engine, explain how to operate and have them read this manual before operation.
- DO NOT modify the engine. UNAUTHORIZED MODIFICATIONS to the engine may impair the function and/or safety and affect engine life. If the engine does not perform properly, consult your local Kubota Engine Distributor first.



1AAACAAAP008B

2. WEAR SAFE CLOTHING AND PERSONAL PROTECTIVE EQUIPMENT (PPE)

- DO NOT wear loose, torn or bulky clothing around the machine that may catch on working controls and projections or into fans, pulleys and other moving parts causing personal injury.
- Use additional safety items-PPE, e.g. hard hat, safety protection, safety goggles, gloves, etc., as appropriate or required.
- DO NOT operate the machine or any equipment attached to it while under the influence of alcohol, medication, or other drugs, or while fatigued.
- DO NOT wear radio or music headphones while operating the engine.



1AEAAAAAP0130

3. CHECK BEFORE STARTING & OPERATING THE ENGINE

- Be sure to inspect the engine before operation. Do not operate the engine if there is something wrong with it. Repair it immediately.
- Ensure all guards and shields are in place before operating the engine. Replace any that are damaged or missing.
- Check to see that you and others are a safe distance from the engine before starting.
- Always keep the engine at least 3 feet (1 meter) away from buildings and other facilities.
- DO NOT allow children or livestock to approach the machine while the engine is running.
- DO NOT start the engine by shorting across starter terminals. The machine may start in gear and move. Do not bypass or defeat any safety devices.



1BAABADAP0010

4. KEEP THE ENGINE AND SURROUNDINGS CLEAN

- Be sure to stop the engine before cleaning.
- Keep the engine clean and free of accumulated dirt, grease and trash to avoid a fire. Store flammable fluids in proper containers and cabinets away from sparks and heat.
- Check for and repair leaks immediately.
- DO NOT stop the engine without idling; Allow the engine to cool down, first. Keep the engine idling for about 5 minutes before stopping unless there is a safety problem that requires immediate shut down.



1AEAAAAAP0120

5. SAFE HANDLING OF FUEL AND LUBRICANTS -KEEP AWAY FROM FIRE

- Always stop the engine before refueling and/or lubricating.
- DO NOT smoke or allow flames or sparks in your work area. Fuel is extremely flammable and explosive under certain conditions.
- Refuel at a well ventilated and open place. When fuel and/or lubricants are spilled, refuel after letting the engine cool down.
- DO NOT mix gasoline or alcohol with diesel fuel. The mixture can cause a fire or severe engine damage.
- Do not use unapproved containers e.g. buckets, bottles, jars. Use approved fuel storage containers and dispensers.

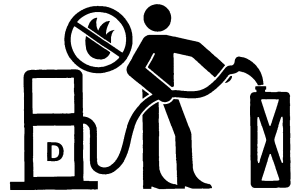

1AAACAAAP001A

6. EXHAUST GASES & FIRE PREVENTION

- Engine exhaust fumes can be very harmful if allowed to accumulate. Be sure to run the engine in a well ventilated location and where there are no people or livestock near the engine.
- The exhaust gas from the muffler is very hot. To prevent a fire, do not expose dry grass, mowed grass, oil or any other combustible materials to exhaust gas. Keep the engine and muffler clean at all times.
- To avoid a fire, be alert for leaks of flammable substances from hoses and lines. Be sure to check for leaks from hoses or pipes, such as fuel and hydraulic fluid by following the maintenance check list.
- To avoid a fire, do not short across power cables and wires. Check to see that all power cables and wirings are in good condition. Keep all electrical connections clean. Bare wire or frayed insulation can cause a dangerous electrical shock and personal injury.
- Make sure there is nothing flammable around diesel particulate filter (hereinafter called DPF) muffler.
- Do not touch the DPF muffler nor get yourself directly exposed to exhaust gases. You may get burnt.



7. ESCAPING FLUID

- Relieve all pressure in the air, the oil and the cooling systems before disconnecting any lines, fittings or related items.
- Relieve all pressure in any system before disconnecting any lines, fittings, or related items. DO NOT check for pressure leaks with your hand. High pressure oil or fuel can cause personal injury.
- Escaping fluid under pressure has sufficient force to penetrate skin causing serious personal injury.
- Fluid escaping from pinholes may be invisible. Use a piece of cardboard or wood to search for suspected leaks: do not use hands and body. Use safety goggles or other eye protection when checking for leaks.
- If injured by escaping fluid, see a medical doctor immediately. This fluid can produce gangrene or severe allergic reaction.

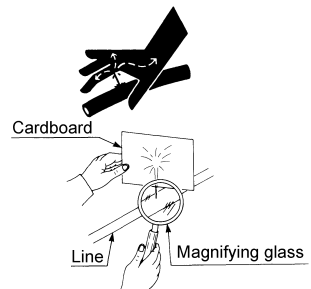

1ABAAAAAP120F

8. CAUTIONS AGAINST BURNS & BATTERY EXPLOSION

- To avoid burns, be cautious of hot components, e.g. DPF muffler, exhaust piping, turbo-charger, EGR system, radiator, hoses, engine body, coolants, engine oil, etc. during operation and after the engine has been shut off.
- DO NOT remove the radiator cap while the engine is running or immediately after stopping. Otherwise hot water will spout out from the radiator. Wait until the radiator is completely cool to the touch before removing the cap. Wear safety goggles.
- Be sure to close the coolant drain valve, secure the pressure cap, and fasten the pipe band before operating. If these parts are taken off, or loosened, it will result in serious personal injury.
- The battery presents an explosive hazard. When the battery is being charged, hydrogen and oxygen gases are extremely explosive.
- DO NOT use or charge the battery if its fluid level is below the LOWER mark. Otherwise, the component parts may deteriorate earlier than expected, which may shorten the service life or cause an explosion. Immediately, add distilled water until the fluid level is between the UPPER and LOWER marks.
- Keep sparks and open flames away from the battery, especially during charging. DO NOT strike a match near the battery.
- DO NOT check the battery charge by placing a metal object across the terminals. Use a voltmeter or hydrometer.
- DO NOT charge a frozen battery. There is a risk of explosion. When frozen, warm the battery up to at least 16°C (61°F).



1AEABAAAP0080

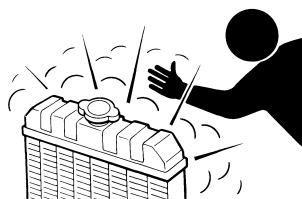

1AAAAABAP0230



1ARAEAAAP0520

9. KEEP HANDS AND BODY AWAY FROM ROTATING PARTS

- Be sure to stop the engine before checking or adjusting the belt tension and cooling fan.
- Keep your hands and body away from rotating parts, such as the cooling fan, V-belt, fan drive pulley or flywheel. Contact with rotating parts can cause severe personal injury.
- DO NOT run the engine without safety guards. Install safety guards securely before operation.



1ABAAAAAP1470

10. ANTI-FREEZE & DISPOSAL OF FLUIDS

- Anti-freeze is poisonous. If it is swallowed, seek immediate medical help. Do NOT make a person throw up unless told to do so by poison control or a health care professional. Use standard first aid and CPR for signs of shock or cardiac arrest. Call your local Poison Control Center or your local emergency number for further assistance.
- Wear rubber gloves to avoid personal injury, when you treat anti-freeze. In case of contact with skin, wash it off immediately.
- DO NOT mix different types of Anti-freeze. The mixture can produce a chemical reaction causing harmful substances. Use approved or genuine KUBOTA Anti-freeze.
- Be mindful of the environment and the ecology. Before draining any fluids, determine the correct way to dispose of them. Observe the relevant environmental protection regulations when disposing of oil, fuel, coolant, brake fluid, filters and batteries.
- When draining fluids from the engine, place a suitable container underneath the engine body.
- DO NOT pour waste onto the ground, down a drain, or into any water source. Dispose of waste fluids according to environmental regulations.



1BJABAAAP0190

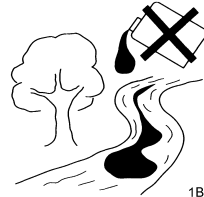

1BJABAAAP0180

11. CONDUCTING SAFETY CHECKS & MAINTENANCE

- When inspecting the engine or servicing, place the engine on a large flat surface. DO NOT work on anything that is supported ONLY by lift jacks or a hoist. Always use blocks or the correct stands to support the engine before servicing.
- Disconnect the battery from the engine before conducting service. Put a "DO NOT OPERATE!" tag on the key switch to avoid accidental starting.
- To avoid sparks from an accidental short circuit always disconnect the battery's ground cable (-) first and reconnect it last.
- Be sure to stop the engine and remove the key when conducting daily and periodic maintenance, service and cleaning.
- Check or conduct maintenance after the engine, coolant, muffler, or muffler cover have cooled off completely.
- Always use the appropriate tools and fixtures. Verify that they are in good condition before performing any service work. Make sure you understand how to use them before service.
- Use ONLY correct engine barring techniques for manually rotating the engine. DO NOT attempt to rotate the engine by pulling or prying on the cooling fan and V-belt. This practice can cause serious personal injury or premature damage to the cooling fan and belt.

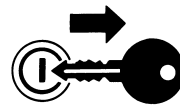

1BJABAAAP0200

- Replace fuel pipes and lubricant pipes with their hose clamps every 2 years or earlier whether they are damaged or not. They are made of rubber and age gradually.
- Keep a first aid kit and appropriate type fire extinguisher handy at all times.

12. WARNING AND CAUTION LABELS

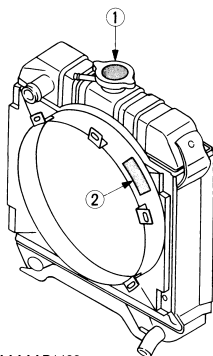

1ABAAAAAP1480

- ① Part No.19077-8724-1 or 16667-8724-1
(55mm in diameter) (37mm in diameter)



1ABACAAAP036K

- ② Part No.TA040-4957-1
Do not get your hands close to engine fan and fan belt.



1AGAMAAAP2620

13. CARE OF WARNING AND CAUTION LABELS

1. Keep warning and caution labels clean and free from obstructing material.
2. Clean warning and caution labels with soap and water, dry with a soft cloth.
3. Replace damaged or missing warning and caution labels with new labels from your local KUBOTA Dealer.
4. If a component with warning and caution label(s) affixed is replaced with a new part, make sure the new label(s) is (are) attached in the same location(s) as the replaced component.
5. Mount new warning and caution labels by applying to a clean dry surface and pressing any bubbles to the outside edge.

SERVICING OF THE ENGINE

Your dealer is interested in your new engine and has the desire to help you get the most value from it. After reading this manual thoroughly, you will find that you can do some of the regular maintenance yourself.

However, when in need of parts or major service, be sure to see your KUBOTA Dealer.

For service, contact the KUBOTA Dealership from which you purchased your engine or your local KUBOTA Dealer.

When in need of parts, be prepared to give your dealer the engine serial number.

Locate the serial number now and record them in the space provided.

	Type	Serial No.
Engine		
Date of Purchase		
Name of Dealer		
(To be filled in by purchaser)		

**[D1803-CR-E4, D1803-CR-TE4,
V2403-CR-E4, V2403-CR-TE4]**

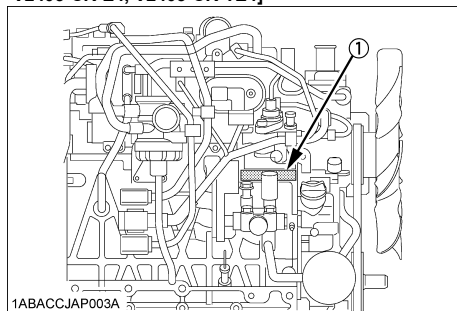

(1) Engine serial number

[V2607-CR-E4, V2607-CR-TE4, V3307-CR-TE4]

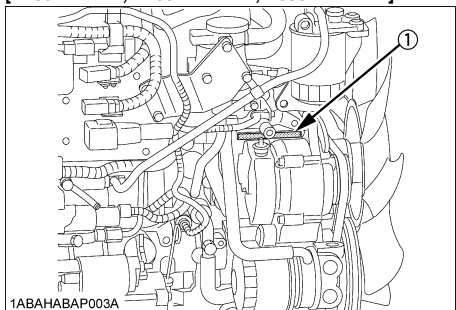

(1) Engine serial number

[V3800-CR-TE4, V3800-CR-TIE4]

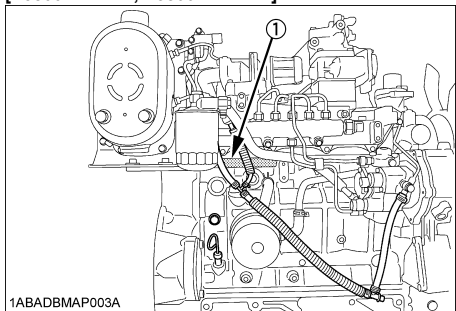

(1) Engine serial number

NAMES OF PARTS

[D1803-CR-E4, D1803-CR-TE4, V2403-CR-E4, V2403-CR-TE4]

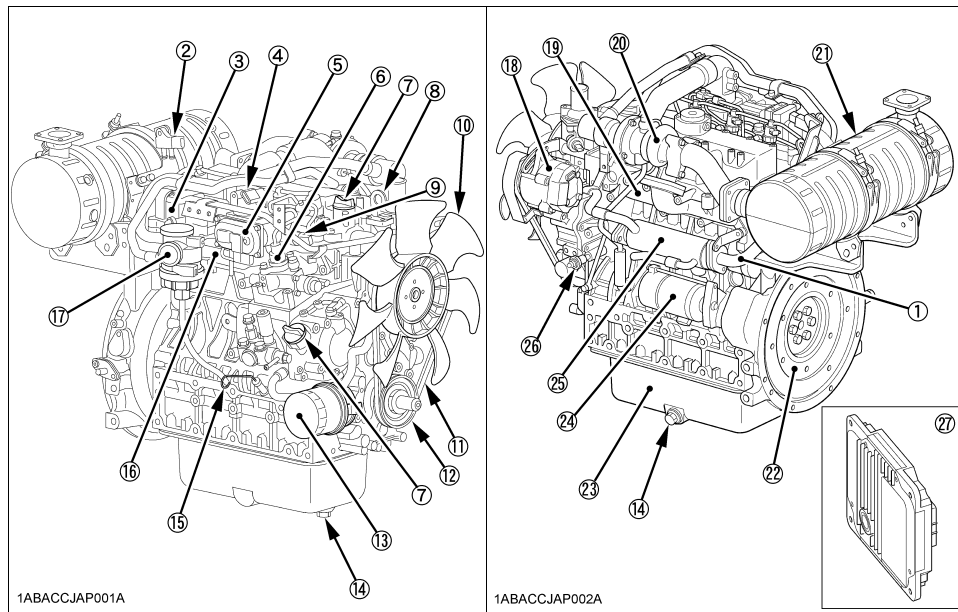

- (1) EGR pipe
- (2) Differential pressure sensor
- (3) EGR valve
- (4) Temperature sensor
- (5) Intake air throttle
- (6) Supply pump
- (7) Oil filler plug
- (8) Engine hook
- (9) Rail
- (10) Cooling fan
- (11) Fan belt
- (12) Fan drive pulley
- (13) Oil filter cartridge
- (14) Oil drain plug

- (15) Oil level gauge
- (16) Intake manifold
- (17) Oil separator
- (18) Alternator
- (19) Exhaust manifold
- (20) Turbo-charger
- (21) Diesel particulate filter (DPF)
- (22) Flywheel
- (23) Oil pan
- (24) Starter
- (25) EGR cooler
- (26) Oil pressure switch
- (27) ECU (Engine Control Unit)

NOTE :

- (27) ECU (Engine Control Unit) is not connected to the engine in the figure above.

[V2607-CR-E4, V2607-CR-TE4, V3307-CR-TE4]

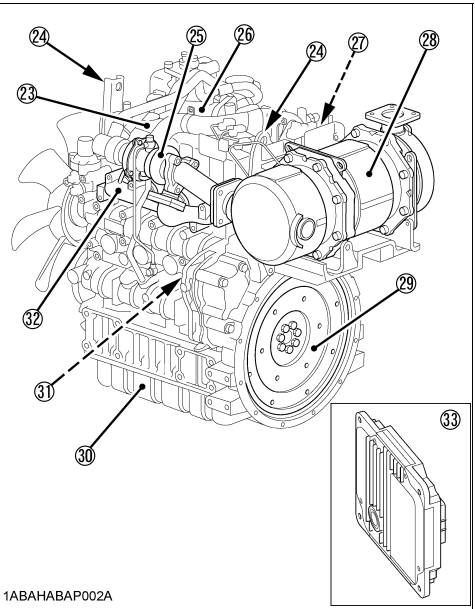
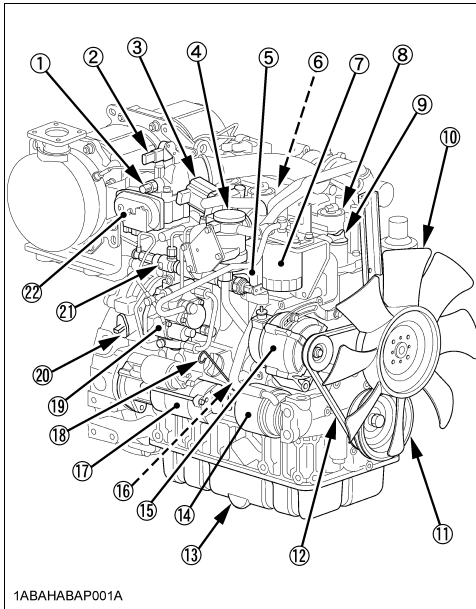

- (1) Temperature sensor
- (2) Differential pressure sensor
- (3) EGR valve
- (4) Oil separator
- (5) Intake manifold
- (6) Glow plug
- (7) Fuel filter cartridge
- (8) Injector
- (9) Oil filler plug
- (10) Cooling fan
- (11) Fan drive pulley
- (12) Fan belt
- (13) Oil drain plug
- (14) Oil filter cartridge
- (15) Alternator
- (16) Oil pressure switch
- (17) Starter

- (18) Oil level gauge
- (19) Supply pump
- (20) NE sensor
- (21) Rail
- (22) Intake air throttle
- (23) Head cover
- (24) Engine hook
- (25) Turbo-charger
- (26) EGR cooler
- (27) Boost sensor
- (28) Diesel particulate filter (DPF)
- (29) Flywheel
- (30) Oil pan
- (31) G sensor
- (32) Exhaust manifold
- (33) ECU (Engine Control Unit)

NOTE :

- (33) ECU (Engine Control Unit) is not connected to the engine in the figure above.

[V3800-CR-TE4, V3800-CR-TIE4]

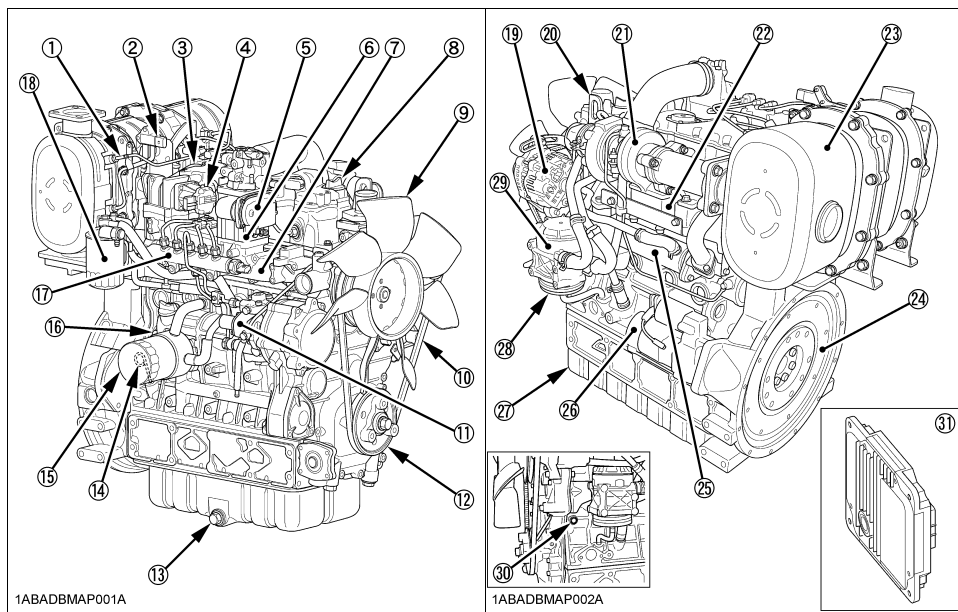

- (1) Temperature sensor
- (2) Differential pressure sensor
- (3) EGR pipe
- (4) EGR valve
- (5) Intake air throttle
- (6) Intake air heater
- (7) Intake manifold
- (8) Oil filler plug
- (9) Cooling fan
- (10) Fan belt
- (11) Supply pump
- (12) Fan drive pulley
- (13) Oil drain plug
- (14) Oil level gauge
- (15) Oil filter cartridge
- (16) Coolant drain cock

- (17) Rail
- (18) Fuel filter cartridge
- (19) Alternator
- (20) Engine hook
- (21) Turbo-charger
- (22) Exhaust manifold
- (23) Diesel particulate filter (DPF)
- (24) Flywheel
- (25) EGR cooler
- (26) Starter
- (27) Oil pan
- (28) PCV valve (Positive Crankcase Ventilation valve)
- (29) Oil separator
- (30) Oil pressure switch
- (31) ECU (Engine Control Unit)

NOTE :

- (31) ECU (Engine Control Unit) is not connected to the engine in the figure above.

PRE-OPERATION CHECK

BREAK-IN

During the engine break-in period, observe the following by all means:

1. Change engine oil and oil filter cartridge after the first 50 hours of operation. (See "Changing of engine oil" and "Replacement of oil filter cartridge" in "EVERY 500 SERVICE HOURS" in "REGULAR CHECKS AND MAINTENANCE WORK" section.)
2. When ambient temperature is low, operate the machine after the engine has been completely warmed up.

DAILY CHECK

To prevent trouble from occurring, it is important to know the conditions of the engine well. Check it before starting.



CAUTION

To avoid personal injury:

- Be sure to install shields and safeguards attached to the engine when operating.
- Stop the engine at a flat and wide space when checking.
- Keep dust or fuel away from the battery, wiring, muffler and engine to prevent a fire. Check and clear them before operating everyday. Pay attention to the heat of the exhaust pipe or exhaust gas so that it can not ignite trash.

Item		Ref. page
1. Parts which had trouble in previous operation		-
2. By walking around the machine	(1) Oil or water leaks	20
	(2) Engine oil level and contamination	13
	(3) Amount of fuel	15
	(4) Amount of coolant	15 to 17
	(5) Dust in air cleaner dust cup	20
	(6) Damaged parts and loosened bolts and nuts	-
3. By inserting the key into the starter switch	(1) Proper functions of meters and pilot lamps; no stains on these parts	-
4. By starting the engine	(1) Color of exhaust fumes	8
	(2) Unusual engine noise	8
	(3) Engine start-up condition	7
	(4) Slow-down and acceleration behavior	8

OPERATING THE ENGINE

STARTING THE ENGINE (NORMAL)



CAUTION

To avoid personal injury:

- Do not allow children to approach the machine while the engine is running.
- Be sure to install the machine on which the engine is installed, on a flat place.
- Do not run the engine on gradients.
- Do not run the engine in an enclosed area. Exhaust gas can cause air pollution and exhaust gas poisoning.
- Keep your hands away from rotating parts (such as fan, pulley, belt, flywheel etc.) during operation.
- Do not operate the machine while under the influence of alcohol or drugs.
- Do not wear loose, torn or bulky clothing around the machine. It may catch on moving parts or controls, leading to the risk of accident. Use additional safety items, e.g. hard hat, safety boots or shoes, eye and hearing protection, gloves, etc., as appropriate or required.
- Do not wear radio or music headphones while operating engine.
- Check to see if it is safe around the engine before starting.
- Reinstall safeguards and shields securely and clear all maintenance tools when starting the engine after maintenance.

IMPORTANT :

- Do not use ether or any starting fluid for starting the engine, or a severe damage will occur.
- When starting the engine after a long storage (of more than 3 months), activate the starter for about 10 seconds to allow oil to reach every engine part.

1. Set the fuel cock to the "ON" (OPEN) position.
2. Insert the key into the key switch.
3. Turn the key to the "ON" position and hold it until the heater indicator turns off.

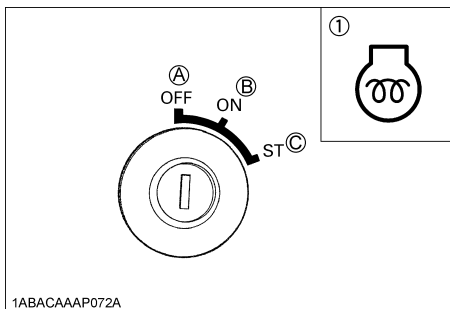

- (1) Heater indicator
 (A) "OFF" SWITCHED OFF
 (B) "ON" OPERATION
 (C) "ST" STARTING

4. Turn the key to the "STARTING" position and the engine should start. Release the key immediately when the engine starts.
5. Check to see that the oil pressure lamp and charge lamp are off. If the lamps are still on, immediately stop the engine, and determine the cause. (See "CHECKS DURING OPERATION" in "OPERATING THE ENGINE" section.)

NOTE :

- If the oil pressure lamp stays on after the engine starts and runs, shut the engine off immediately and check the following:
 - if there is enough engine oil.
 - if the engine oil has dirt in it.
 - if the wiring is faulty.
 If the oil pressure lamp continues to stay on and is not resolved by checking these items, contact your local KUBOTA Dealer for service.

6. Warm up the engine at medium speed without load.

IMPORTANT :

- If the engine does not catch or start at 10 seconds after the starter switch is set at "STARTING" position, wait for another 30 seconds and then begin the engine starting sequence again. Do not allow the starter motor to run continuously for more than 20 seconds.
- If a DPF overheat warning is indicated, keep in mind that the engine cannot get restarted until the DPF temperature drops below 300°C (572°F).

COLD WEATHER STARTING

If the ambient temperature is below -5°C(23°F) and the engine is very cold, start it in the following manner:

Take steps (1) through (2) above.

3. Turn the key to the "ON" position and hold it until the heater indicator turns off.

Heater indicator comes on when the key is turned to the "ON" position and engine coolant temperature is below 0° C (32 °F), and goes off automatically when preheat is completed.

4. Turn the key to the "STARTING" position and the engine should start.

(If the engine fails to start after 10 seconds, turn off the key for 30 seconds. Then repeat steps (3) and (4).

IMPORTANT :

- Do not allow the starter motor to run continuously for more than 20 seconds.
- Be sure to warm up the engine, not only in winter, but also in warmer seasons. An insufficiently warmed-up engine can shorten its service life.
- When the ambient temperature is expected to be below -15° C (5° F), remove the battery from the machine and move it to a warmer or heated and safe indoor location. Reinstall the battery in the machine just prior to the next machine usage. Do not store the battery in living areas. Please observe Cautions under section 8. in "SAFE OPERATION" of this manual when working on or handling the battery or personal injury and property damage may occur.

STOPPING THE ENGINE



CAUTION

To avoid personal injury:

- To stop the engine, be sure to use the key switch.

When shutting off the battery power directly with the battery switch or the like, first stop the engine with the key switch and then make sure the ECU and the SCR system comes to a complete stop.

Otherwise a trouble or malfunction may be caused.

1. Run the engine under idling conditions.

IMPORTANT :

- Allow the engine to idle for 5 minutes before shutting it off after a full load operation.
Failure to do so may lead to turbo-charger trouble.

2. The engine should stop with the starter switch placed at the "OFF" position.

3. After stopping the engine, remove the key.

CHECKS DURING OPERATION

While running, make the following checks to see that all parts are working correctly.

■ Radiator cooling water (Coolant)



WARNING

To avoid personal injury:

- Do not remove radiator cap until coolant temperature is well below its boiling point. Then loosen cap slightly to the stop position, to relieve any pressure, before removing cap completely.

If the coolant temperature warning lamp lights up or if steam or coolant does not stop squirting from the radiator overflow pipe, turn off the load and **keep the engine idling (COOLING-DOWN) for at least 5 minutes** to let it cool down gradually. Then stop the engine and take the following inspection and servicing.

1. Check to see if the coolant runs short or if there is any coolant leak;
2. Check to see if there is any obstacle around the cooling air inlet or outlet;
3. Check to see if there is any dirt or dust between radiator fins and tube;
4. Check to see if the fan belt is too loose; and
5. Check to see if radiator water pipe is clogged.

■ Oil pressure lamp

The lamp lights up to warn the operator that the engine oil pressure has dropped below the prescribed level. If this should happen during operation or should not go off even after the engine is accelerated more than 1000rpm, immediately stop the engine and check the following:

1. Engine oil level (See "Checking of engine oil level" in "DAILY CHECKS" in "MAINTENANCE" section.)

■ Charge lamp

The charge lamp lights up to warn the operator the battery charge is low during running or there is no alternator output during running. It is normal to have the charge lamp on when the key is on and engine is not running.

If the charge lamp is on during running, check the following:

1. Cable broken
2. Poor connection at alternator terminal
3. Fan belt too loose or damaged

■ Fuel



CAUTION

To avoid personal injury:

- Fluid escaping from pinholes may be invisible. Do not use hands to search for suspected leaks; Use a piece of cardboard or wood, instead. If injured by escaping fluid, see a medical doctor at once. This fluid can produce gangrene or a severe allergic reaction.
- Check any leaks from fuel pipes. Use eye, face and hand protection such as gloves and any necessary appropriate additional personal protective equipment and clothing.

Do not run the fuel tank level too low or completely out of fuel. You may experience improper engine running and/or a DTC (Diagnostic Trouble Code) error code may be recorded in the Engine Control. Additionally, fuel system bleeding may be necessary if air enters the fuel system. (See "Checking of fuel level" in "DAILY CHECKS" in "MAINTENANCE" section.)

■ Color of exhaust

White exhaust may come out. In most cases this is caused by water vapor and not a problem. Such exhaust disappears when the temperature rises up as specified.

■ Immediately stop the engine if;

- The engine suddenly slows down or accelerates.
- Unusual noises are suddenly heard.
- Exhaust fumes suddenly become very dark.
- The oil pressure lamp lights up.
- The engine warning lamp lights up.
- Continuous large or abnormal quantities of white smoke.

DIESEL PARTICULATE FILTER (DPF)

This filter serves to trap particulate matters (PM) that are contained in exhaust gases and to automatically burn (DPF-regenerate) these matters. To keep the DPF at full capacity, be sure to keep the following instructions in mind.

- Be sure to use ultralow-sulfur light diesel oil (below S15 ppm) as fuel.
- Be sure to use CJ-4 or CK-4 engine oil. Incorrect engine oil may cause plugging of the DPF and lower fuel economy.
- Do not tamper with the DPF. It could be damaged or malfunction, causing expensive repairs.
- Do not use any falling DPF again. Because the DPF has a catalyst inside, a strong impact may damage the DPF.

AIR FLOW SENSOR

■ Air cleaner-mounted type

- Do not use any other air cleaner and element than specified. Unspecified ones cause the air flow sensor to malfunction and to lose its full performance.

■ Inlet hose pipe-mounted type

- Be careful not to install the air flow sensor on the pipe in the wrong direction.
- Do not change the direction and insertion angle of the hoses before and after the pipe. Wrong direction causes the air flow sensor to malfunction and to lose its full performance.

PRECAUTIONS ON GENERATOR-EQUIPPED ENGINE



CAUTION

To avoid personal injury:

If the engine is kept running under no load or light load (load factor below 30%), unburnt fuel or carbon builds up in the exhaust system. As a result, the engine may get damaged or cause a fire. Run the engine under enough load at regular intervals to remove unburnt fuel and carbon deposits.

- Before doing the load operation, make sure there is nothing flammable around the engine.
- Do not put a load all at once on the engine, but gradually.
- If by any chance, spark rises out of the muffler outlet, **DO NOT GET THE ENGINE UNLOADED, BUT INTERRUPT IT IMMEDIATELY.**

MAINTENANCE

IMPORTANT :

- A repair shop or person of the owner's choosing may maintain, replace, or repair emission-control devices and systems. However, warranty service must be performed by an authorized KUBOTA service facility except in the case of emergency.

**CAUTION**

To avoid personal injury:

- Be sure to conduct daily checks, periodic maintenance, refueling or cleaning on a level surface with the engine shut off and remove the key.
- Before allowing other people to use your engine, explain how to operate, and have them read this manual before operation.
- When cleaning any parts, do not use gasoline but use regular cleanser.
- Always use proper tools, that are in good condition. Make sure you understand how to use them, before performing any service work.
- When installing, be sure to tighten all bolts lest they should be loose. Tighten the bolts by the specified torque.
- Do not put any tools on the battery, or battery terminals may short out. Severe burns or fire could result. Detach the battery from the engine before maintenance.
- Do not touch muffler or exhaust pipes while they are hot; Severe burns could result.

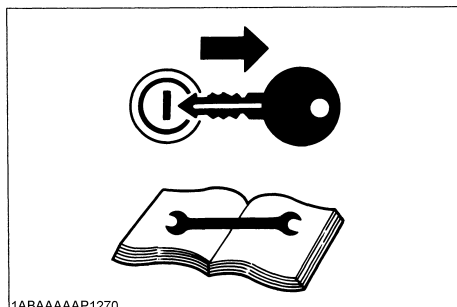

1ABAAAAAP1270



1ABAAAAAP1280

SERVICE INTERVALS

Observe the following for service and maintenance.

Interval	Item	Ref. page		
Daily	Checking of engine oil level	13		
	Checking of fuel level	15		
	Checking of coolant level	15		
	Checking of fan belt	18		
Every 50 hours	Checking of fuel pipes and clamp bands	19		
	Draining of water separator (Type 1)	19		
Every 250 hours	Checking of radiator hoses and clamp bands	20		
	Cleaning of air cleaner element	20	*1	
	Adjustment of fan belt tension	21		
	Checking of intake air line	21		
Every 400 hours	D1803-CR-E4, D1803-CR-TE4, V2403-CR-E4, V2403-CR-TE4	Changing of engine oil	22	⊙
		Replacement of oil filter cartridge	22	⊙
Every 500 hours	V2607-CR-E4, V2607-CR-TE4, V3307-CR-TE4, V3800-CR-TE4, V3800-CR-TIE4	Changing of engine oil	23	⊙
		Replacement of oil filter cartridge	23	⊙
		Replacement of fuel filter cartridge	24	
		Removal of sediment in fuel tank	24	*3
		Cleaning of water jacket (radiator interior)	24	*3
		Replacement of fan belt	24	*3
		Cleaning of water separator (Type 1)	24	*3
Every 500 hours or 1 year	Replacement of water separator filter (Type 2)	24	*3	
Every 1000 hours	Checking of valve clearance	24	*3	
Every 1500 hours	Checking of injector tip	24	*3	@
	Checking of EGR cooler	24	*3	@
	Changing of oil separator element	25		@
	V3800-CR-TE4, V3800-CR-TIE4	Checking of PCV valve	25	*3
Every 3000 hours	Checking of turbo-charger	26	*3	@
	Cleaning of DPF	26	*3	@
	Checking of EGR system	26	*3	@

Interval	Item	Ref. page		
Every year	Replacement of air cleaner element	26	*2 *3	
	Checking of DPF related piping	26	*3	
	Checking of EGR piping	26	*3	
	Checking of intake air line	26		
	Checking of exhaust manifold for cracks or gas leak and for looseness or damage	26		
Every 2 years	Replacement of oil separator related rubber piping	26	*3	
	Replacement of DPF related rubber piping	26	*3	
	Replacement of intake air line and suction air pressure takeout rubber piping	26	*3	
	Replacement of boost sensor pressure rubber piping	26	*3	
	Replacement of EGR cooler rubber piping	26	*3	
	Replacement of water rubber piping	26	*3	
	Replacement of lubricant rubber piping	26	*3	
	Changing of radiator coolant (L.L.C.)	27		
	Replacement of radiator hoses and clamp bands	27	*3	
	Replacement of fuel pipes and clamp bands	27	*3	
	Replacement of intake air line	27	*3	
Replacement of fan belt (or every 500 hours)	27	*3		
SERVICE AS REQUIRED	Draining of water separator (Type 2)	27	*3	

IMPORTANT :

- The jobs indicated by © must be done after the first 50 hours of operation.

*1 Air cleaner should be cleaned more often in dusty conditions than in normal conditions.

*2 After 6 times of cleaning.

*3 Consult your local KUBOTA Dealer for this service.

- The items listed above (@ marked) are registered as emission related critical parts by KUBOTA in the U.S. EPA nonroad emission regulation. As the engine owner, you are responsible for the performance of the required maintenance on the engine according to the above instruction.

Please see the Warranty Statement in detail.

- The items listed above other than @ marked are not necessary to keep the emission-related warranty valid.
- Failure to perform the maintenance will cause problems that will significantly degrade the engine performance.

■ Water separator

[Type 1]

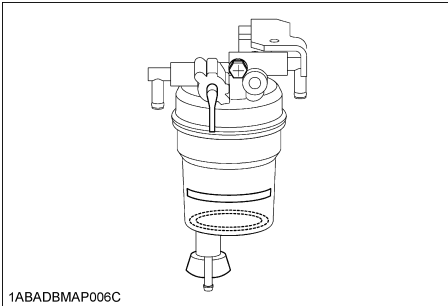

1ABADBMAP006C

[Type 2]

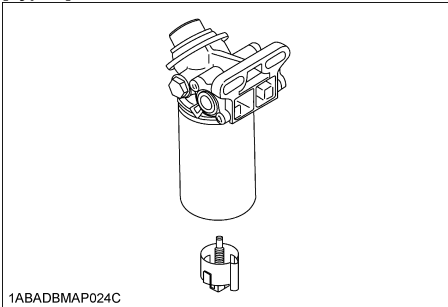

1ABADBMAP024C

DAILY CHECKS

For your own safety and to assure the long life of your machine, a careful check should be made before each operation.

■ Checking of engine oil level

CAUTION

To avoid personal injury:

- Be sure to stop the engine before checking and changing the engine oil and the oil filter cartridge.
- Do not touch muffler or exhaust pipes while they are hot; Severe burns could result. Always stop the engine and allow it to cool before conducting inspections, maintenance, or for a cleaning procedure.
- Contact with engine oil can damage your skin. Put on gloves when using engine oil. If you come in contact with engine oil, wash it off immediately.

IMPORTANT :

- Do not operate a diesel engine when engine oil is overfilled. This oil can drain through the air intake system, which cause engine disacceleration and oil leaks from breather piping. It could result in a overrunning or oil hammering of engine in case of the engine with suction blow-by gases breathed in.

1. Check the engine oil level before starting or more than 5 minutes after stopping the engine.
2. Remove the oil level gauge, wipe it clean and reinstall it.
3. Take the oil level gauge out again, and check the oil level.

[D1803-CR-E4, D1803-CR-TE4, V2403-CR-E4, V2403-CR-TE4]

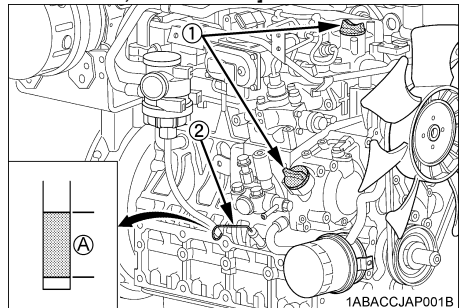

1ABACCJAP001B

- (1) Oil filler plug [Lower end of oil level gauge]
- (2) Oil level gauge (A) Engine oil level within this range is proper.

[V2607-CR-E4, V2607-CR-TE4, V3307-CR-TE4]

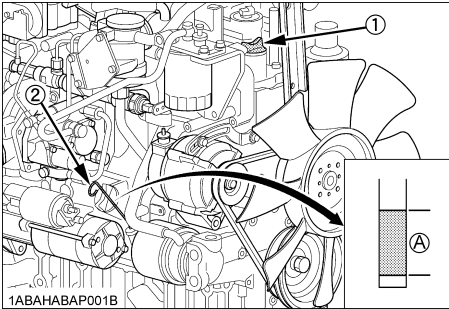

- (1) Oil filler plug [Lower end of oil level gauge]
 (2) Oil level gauge (A) Engine oil level within this range is proper.

[V3800-CR-TE4, V3800-CR-TIE4]

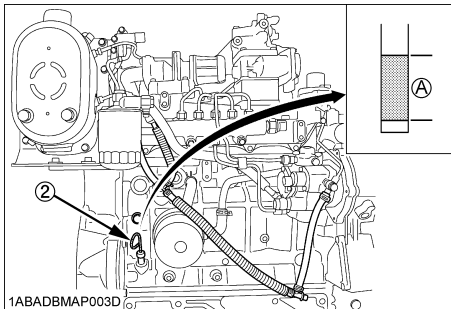
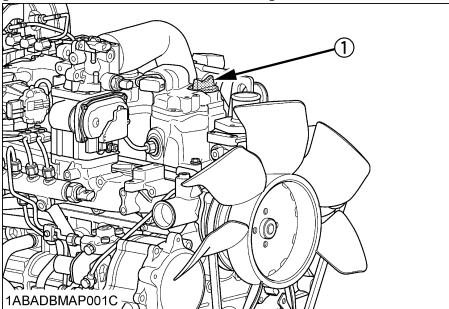

- (1) Oil filler plug [Lower end of oil level gauge]
 (2) Oil level gauge (A) Engine oil level within this range is proper.

- If the oil level is too low, remove the oil filler plug, and add new oil to the prescribed level.
- After adding oil, wait more than 5 minutes and check the oil level again. It takes some time for the oil to drain down to the oil pan.

Models	Engine oil quantity
D1803-CR-E4 D1803-CR-TE4	7.0 L (1.85 U.S.gals.)
V2403-CR-E4 V2403-CR-TE4	9.5 L (2.51 U.S.gals.)
V2607-CR-E4 V2607-CR-TE4	10.2 L (2.24 U.S.gals.)
V3307-CR-TE4	11.2 L (2.95 U.S.gals.)
V3800-CR-TE4 V3800-CR-TIE4	13.2 L (3.49 U.S.gals.)

IMPORTANT :

- Engine oil should be API classification CJ-4 or CK-4.
- Change the type of engine oil according to the ambient temperature.

Above 25°C (77°F)	10W-30 or 10W-40 or 15W-40
-10°C to 25°C (14°F to 77°F)	10W-30 or 10W-40 or 15W-40
Below -10°C (14°F)	10W-30 or 10W-40

- When using oil of different brands from the previous one, be sure to drain all the previous oil before adding the new engine oil.
- Use of the following oil not only disallows the engine from performing well in low temperatures until it warms up sufficiently but may also lead to excessive engine wear or engine seizure.
 - Oil with a viscosity higher than 10W-30
 - Oil not recommended by KUBOTA
- On DPF-equipped engines, part of the fuel may get mixed with engine oil during the regenerating process. This may dilute the oil and increase its quantity. If the oil rises above the oil level gauge upper limit, it means the oil has been diluted too much, resulting in a trouble. In such case, immediately change the oil for new one.
 - If the interval of DPF regeneration becomes 5 hours or less, be sure to change the oil for new one.

NOTE :

- Be sure to inspect the engine, locating it on a level place. If placed on gradients accurately, oil quantity may not be measured.

■ **Checking of fuel level**

Fuel is flammable and can be dangerous. You should handle fuel with care.



CAUTION

To avoid personal injury:

- **Do not mix gasoline or alcohol with diesel fuel. This mixture can cause an explosion.**
- **Be careful not to spill fuel during refueling. If fuel should spill, wipe it off at once, or it may cause a fire.**
- **Do not fail to stop the engine before refueling. Keep the engine away from the fire.**
- **Be sure to stop the engine while refueling or bleeding and when cleaning or changing fuel filter or fuel pipes. Do not smoke when working around the battery or when refueling.**
- **Check the fuel systems at a well ventilated and wide place.**

1. Check to see that the fuel level is above the lower limit of the fuel level gauge.
2. If the fuel is too low, add fuel to the upper limit. Do not overflow.

- **Cetane Rating** : The minimum recommended Fuel Cetane Rating is 45. A cetane rating greater than 50 is preferred, especially for ambient temperatures below -20°C (-4°F) or elevations above 1500 m (5000 ft).
- **Diesel Fuel Specification Type and Sulfur Content** (ppm) used, must be compliant with all applicable emission regulations for the area in which the engine is operated.
- **DO NOT USE Fuels** that have sulfur content greater than 0.0015 % (15 ppm).
- **Diesel fuels** specified to EN 590 or ASTM D975 are recommended.
- **No.2-D** is a distillate fuel of lower volatility for engines in industrial and heavy mobile service. (SAE J313 JUN87)
- **[D1803-CR-E4, D1803-CR-TE4, V2403-CR-E4, V2403-CR-TE4, V2607-CR-E4, V2607-CR-TE4, V3307-CR-TE4]**

These engines utilize Tier 4 standards, the use of ultra low sulfur fuel is mandatory for these engines, when operated in US EPA regulated areas. Therefore, please use No.2-D S15 diesel fuel as an alternative to No.2-D, and use No.1-D S15 diesel fuel as an alternative to No.1-D for ambient temperatures below -10 °C (14 °F).

[V3800-CR-TE4, V3800-CR-TIE4]

These engines utilize Interim Tier 4 standards, the use of ultra low sulfur fuel is mandatory for these engines, when operated in US EPA regulated areas. Therefore, please use No.2-D S15 diesel fuel as an alternative to No.2-D, and use No.1-D S15 diesel fuel as an alternative to No.1-D for ambient temperatures below -10 °C (14 °F).

- 1) SAE : Society of Automotive Engineers
- 2) EN : European Norm
- 3) ASTM : American Society of Testing and Materials
- 4) US EPA : United States Environmental Protection Agency
- 5) No.1-D or No.2-D, S15 : Ultra Low Sulfur Diesel (ULSD) 15 ppm or 0.0015 wt.%

IMPORTANT :

- Be sure to use a strainer when filling the fuel tank, or dirt or sand in the fuel may cause trouble.
- Do not run the fuel tank level too low or completely out of fuel. You may experience improper engine running and/or a DTC (Diagnostic Trouble Code) error code may be recorded in the Engine Control. Additionally, fuel system bleeding may be necessary if air enters the fuel system.
- Fuel must be controlled carefully to prevent the additives being mixed into fuel such as fuel tank anti-oxidants, water remover, anti-freeze and so on.

■ **Checking of coolant level**

Coolant will last for one day's work if filled all the way up before operation start. Make it a rule to check the coolant level before every operation.



WARNING

To avoid personal injury:

- **Do not stop the engine suddenly, stop it after about 5 minutes of unloaded idling.**
- **Work only after letting the engine and radiator cool off completely (more than 30 minutes after it has been stopped).**
- **Do not remove the radiator cap while coolant is hot. When cool to the touch, rotate cap to the first stop to allow excess pressure to escape. Then remove cap completely. If overheats should occur, steam may gush out from the radiator or recovery tank; Severe burns could result.**

1. Remove the radiator cap, after the engine has completely cooled, and check to see that coolant reaches the supply port.

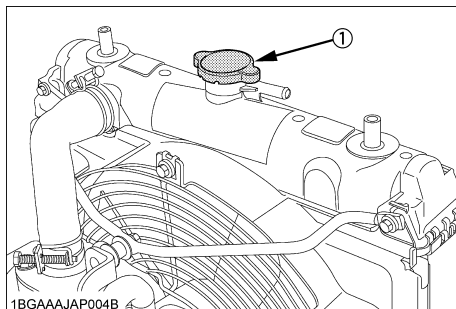

1BGAAAJAP004B

(1) Radiator pressure cap

2. If the radiator is provided with a recovery tank, check the coolant level of the recovery tank. When it is between the "FULL" and "LOW" marks, the coolant will last for one day's work.

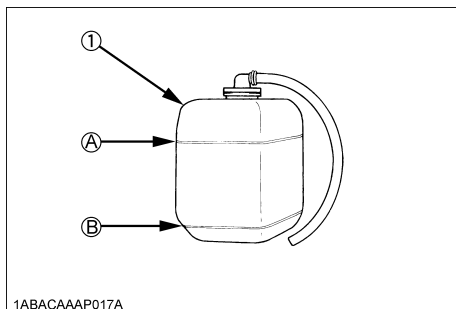

1ABACAAAP017A

(1) Recovery tank

(A) "FULL"

(B) "LOW"

3. When the coolant level drops due to evaporation, add water only up to the full level.

[D1803-CR-E4, D1803-CR-TE4, V2403-CR-E4, V2403-CR-TE4, V2607-CR-E4, V2607-CR-TE4, V3307-CR-TE4]

4. Check to see the drain cock; which is at the lower part of the radiator as figures below.

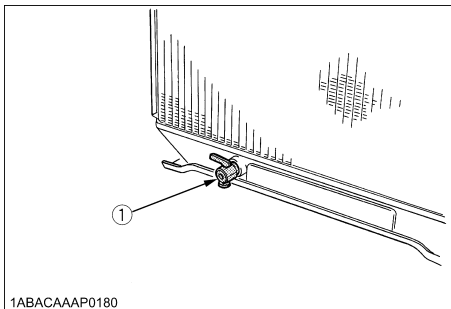

1ABACAAAP0180

(1) Coolant drain cock

[V3800-CR-TE4, V3800-CR-TIE4]

4. Check to see that two drain cocks; one is at the crankcase side and the other is at the lower part of the radiator as figures below.

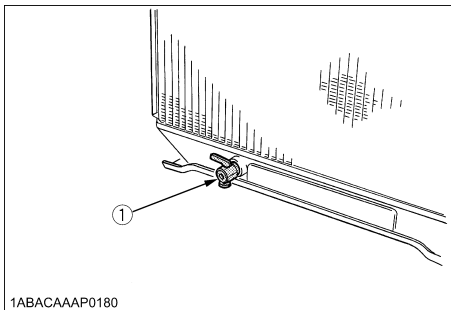
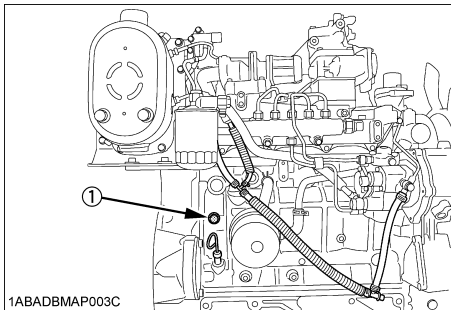

(1) Coolant drain cock

IMPORTANT :

- If the radiator cap has to be removed, follow the caution and securely retighten the cap.
- If coolant should be leak, consult your local KUBOTA Dealer.
- Make sure that muddy or sea water does not enter the radiator.
- Use clean, fresh water and 50% anti-freeze to fill the recovery tank.
- Do not refill recovery tank with coolant over the "FULL" level mark.
- Be sure to close the radiator cap securely. If the cap is loose or improperly closed, coolant may leak out and decrease quickly.

■ Anti-freeze



CAUTION

To avoid personal injury:

- When using anti-freeze, put on some protection such as rubber gloves (Anti-freeze is poisonous.).
- If it is swallowed, seek immediate medical help. Do NOT make a person throw up unless told to do so by poison control or a health care professional. Use standard first aid and CPR for signs of shock or cardiac arrest. Call your local Poison Control Center or your local emergency number for further assistance.
- When anti-freeze comes in contact with the skin or clothing, wash it off immediately.
- Do not mix different types of anti-freeze. The mixture can produce chemical reaction causing harmful substances.
- Anti-freeze is extremely flammable and explosive under certain conditions. Keep fire and children away from anti-freeze.
- When draining fluids from the engine, place some container underneath the engine body.
- Do not pour waste onto the grounds, down a drain, or into any water source.
- Also, observe the relevant environmental protection regulations when disposing of anti-freeze.

Always use a 50/50 mix of long-life coolant and clean soft water in KUBOTA engines.

Contact KUBOTA concerning coolant for extreme conditions.

1. Long-life coolant (hereafter LLC) comes in several types. Use ethylene glycol (EG) type for this engine.
2. Before employing LLC-mixed cooling water, flush the radiator with fresh water. Repeat this procedure 2 or 3 times to clean up the radiator and engine block from inside.
3. Mixing the LLC
Premix 50% LLC with 50% clean soft water. When mixing, stir it up well, and then fill into the radiator.

4. The procedure for the mixing of water and anti-freeze differs according to the make of the anti-freeze. Refer to SAE J1034 standard, more specifically also to SAE J814c.

Vol % Anti-freeze	Freezing Point		Boiling Point *	
	°C	°F	°C	°F
50	-37	-34	108	226

*At 1.013×10^5 Pa (760 mmHg) pressure (atmospheric). A higher boiling point is obtained by using a radiator pressure cap which permits the development of pressure within the cooling system.

5. Adding the LLC
- (1) Add only water if the coolant level reduces in the cooling system by evaporation.
 - (2) If there is a coolant leak, add the LLC of the same manufacturer and type in the same coolant percentage.
- *Never add any long-life coolant of different manufacturer. (Different brands may have different additive components, and the engine may fail to perform as specified.)
6. When the LLC is mixed, do not employ any radiator cleaning agent. The LLC contains anti-corrosive agent. If mixed with the cleaning agent, sludge may build up, adversely affecting the engine parts.
7. Kubota's genuine long-life coolant has a service life of 2 years. Be sure to change the coolant every 2 years.

NOTE :

- The above data represents industry standards that necessitate minimum glycol content in the concentrated anti-freeze.

■Checking of fan belt

(See "Adjustment of fan belt tension" in "EVERY 250 SERVICE HOURS" in "REGULAR CHECKS AND MAINTENANCE WORK" section.)

REGULAR CHECKS AND MAINTENANCE WORK

EVERY 50 SERVICE HOURS

■ Checking of fuel pipes and clamp bands



CAUTION

To avoid personal injury;

- Stop the engine before checking or replacing the fuel pipes. Broken fuel pipes can cause fires.

Check the fuel pipes every 50 hours of operation. When if;

1. If the clamp band is loose, apply oil to the screw of the band, and tighten the band securely.
2. If the fuel pipes, made of rubber, become worn out, replace them and clamp bands every 2 years.
3. If the fuel pipes and clamp bands are found worn or damaged before 2 years' pass, replace or repair them at once.

[D1803-CR-E4, D1803-CR-TE4,
V2403-CR-E4, V2403-CR-TE4]

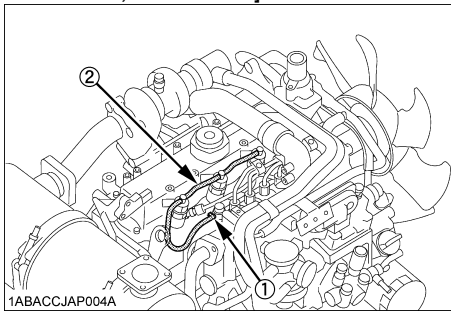

- 1ABACCJAP004A
- (1) Clamp band
 - (2) Fuel pipe

[V2607-CR-E4, V2607-CR-TE4, V3307-CR-TE4]

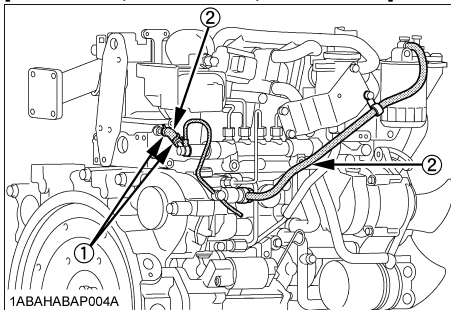

- 1ABAHABAP004A
- (1) Clamp band
 - (2) Fuel pipe

[V3800-CR-TE4, V3800-CR-TIE4]

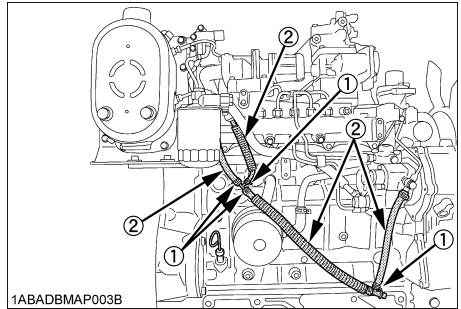

1ABADBMAP003B

- (1) Clamp band
- (2) Fuel pipe

■ Draining of water separator (Type 1)

[Checking and Draining]

Water and dirt contained in fuel will settle down in the water separator. When such foreign substances are deposited, set the water separator handle to the "CLOSE" position. Loosen the top screw first and then the bottom cock to let the foreign substances out of the separator.

Finally be sure to air-bleed the fuel system.

[Cleaning]

1. Set the water separator handle to the "CLOSE" position.
2. Loosen and remove the cup proper, and clean its inside with light oil.
3. Tighten up the cup proper.

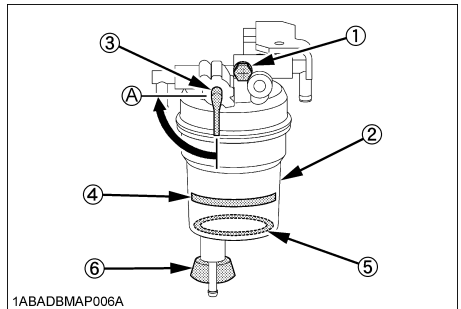

1ABADBMAP006A

- (1) Screw
 - (2) Cup
 - (3) Water separator handle
 - (4) Line
 - (5) Float
 - (6) Cock
- (A) Close

IMPORTANT :

- As water is collected, the red float goes up. When the float has reached the specified line, immediately drain the water separator.
- In reattaching the water separator, be careful to keep off dust and dirt.
- Be sure to air-bleed the fuel system before getting the engine restarted.

EVERY 250 SERVICE HOURS**■ Checking of radiator hoses and clamp bands****CAUTION**

To avoid personal injury:

- **Be sure to check radiator hoses and clamp bands periodically. If radiator hose is damaged or coolant leaks, overheats or severe burns could occur.**

Check to see if radiator hoses are properly fixed every 250 hours of operation or 6 months, whichever comes first.

1. If hose clamps are loose or water leaks, tighten hose clamp securely.
2. Replace hoses and tighten hose clamps securely, if radiator hoses are swollen, hardened or cracked.

Replace hoses and hose clamps every 2 years or earlier, if checked and found that hoses are swollen, hardened or cracked.

■ Precaution at overheating

The event that the coolant temperature is nearly or more than the boiling point is called "**OVERHEATING**".

While running, make the following checks to see that all parts are working correctly. **If anything is unusual, inspect it, referring to the relevant description in "MAINTENANCE" and "REGULAR CHECKS AND MAINTENANCE WORK" section.**

◆ Coolant

If the coolant temperature warning lamp lights up or if steam or coolant does not stop squirting from the radiator overflow pipe, turn off the load and **keep the engine idling (COOLING-DOWN) for at least 5 minutes** to let it cool down gradually. Then stop the engine and take the following inspection and servicing.

1. Check to see if the coolant runs short or if there is any coolant leak;
2. Check to see if there is any obstacle around the cooling air inlet or outlet;
3. Check to see if there is any dirt or dust between radiator fins and tube;
4. Check to see if the fan belt is too loose; and
5. Check to see if radiator water pipe is clogged.

■ Cleaning of air cleaner element

Since the air cleaner employed on this engine is a dry type, never apply oil to it.

1. Open the evacuator valve once a week under ordinary conditions - or daily when used in a dusty place. This will get rid of large particles of dust and dirt.
2. Wipe the inside air cleaner clean with cloth if it is dirty or wet.
3. Avoid touching the element except when cleaning.
4. When dry dust adheres to the element, blow compressed air from the inside turning the element. Pressure of compressed air must be under 205 kPa (2.1 kgf/cm², 30 psi).
5. Replace the primary element every year or every 6 cleanings. If the primary element is stained heavily, replace it soon. At this time, replace the secondary element too.
6. The secondary element should be removed only if it is to be replaced.
7. To protect the engine, do not remove the secondary element in servicing the primary element.

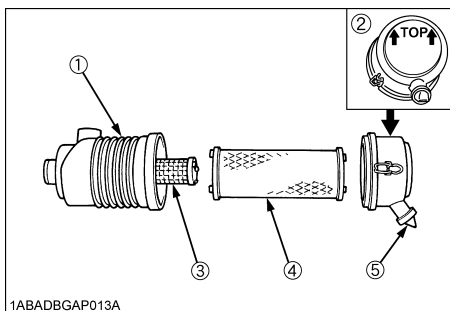

1ABADBGP013A

- (1) Air cleaner body
- (2) Dust cup
- (3) Secondary element
- (4) Primary element
- (5) Evacuator valve

IMPORTANT :

- Make sure the hooking clip for the element is tight enough. If it is loose, dust and dirt may be sucked in, wearing down the cylinder liner and piston ring earlier and thereby resulting in poor power output.
- Do not overservice the air cleaner element. Overservicing may cause dirt to enter the engine causing premature wear. Use the dust indicator as a guide on when to service.

◆ **Cleaning primary air cleaner element**

- To clean the element, use clean dry compressed air on the inside of the element.
Air pressure at the nozzle must not exceed 205 kPa (2.1kgf/cm², 30psi).
Maintain reasonable distance between the nozzle and the filter.

■ **Adjustment of fan belt tension**



CAUTION

To avoid personal injury:

- Be sure to stop the engine and remove the key before checking the belt tension.
- Be sure to reinstall the detached safety shield after maintenance or checking.

- Stop the engine and remove the key.
- Apply moderate thumb pressure to belt between the pulleys.
- If tension is incorrect, loosen the alternator mounting bolts and, using a lever placed between the alternator and the engine block, pull the alternator out until the deflection of the belt falls within acceptable limits.
- Replace fan belt if it is damaged.

IMPORTANT :

- If belt is loosen or damaged and the fan is damaged, it could result in overheats or insufficient charging. Correct or replace belt.

Proper fan belt tension	A deflection (A) when the belt is pressed in the middle of the span.
-------------------------	--

Models	(A)
D1803-CR-E4 D1803-CR-TE4 V2403-CR-E4 V2403-CR-TE4	7 to 9 mm (0.28 to 0.35 in.) (under load of 10 kgf (22.1 lbs))
V2607-CR-E4 V2607-CR-TE4 V3307-CR-TE4	10 to 12 mm (0.39 to 0.47 in.) (under load of 10 kgf (22.1 lbs))
V3800-CR-TE4 V3800-CR-TIE4	10 to 12 mm (0.39 to 0.47 in.) (under load of 6 to 7 kgf (13.2 to 15.4 lbs))

[D1803-CR-E4, D1803-CR-TE4, V2403-CR-E4, V2403-CR-TE4]

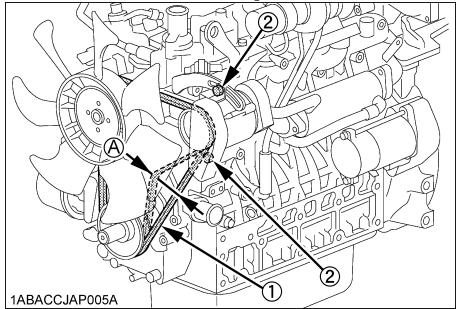

- Fan belt
- Bolt and nut

[V2607-CR-E4, V2607-CR-TE4, V3307-CR-TE4]

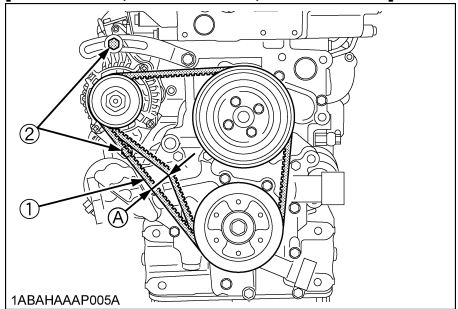

- Fan belt
- Bolt and nut

[V3800-CR-TE4, V3800-CR-TIE4]

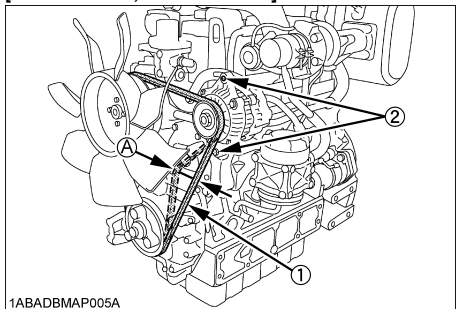

- Fan belt
- Bolt and nut

■ **Checking of intake air line**

Visually check for cracks, gas leak and anything else unusual.
Check to see if the lock bolts and nuts are tight enough.

EVERY 400 SERVICE HOURS

■ Changing of engine oil

[D1803-CR-E4, D1803-CR-TE4, V2403-CR-E4, V2403-CR-TE4]



CAUTION

To avoid personal injury:

- Be sure to stop the engine before draining engine oil.
- When draining engine oil, place some container underneath the engine and dispose it according to local regulations.
- Do not drain oil after running the engine. Allow engine to cool down sufficiently.

1. Change oil after the initial 50 hours of operation and every 400 hours thereafter. When the annual operating hours are below 400, replace the oil every year.
2. Remove the drain plug at the bottom of the engine, and drain all the old oil. Drain oil will drain easier when the oil is warm.

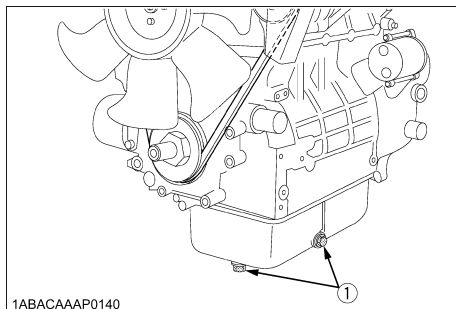

1ABACAAAP0140

- (1) Oil drain plug
3. When letting out the oil, remove the filler plug too. With the filler plug still in place, it would be difficult to discharge the oil completely.
4. Add new engine oil up to the upper limit of the oil level gauge. Be careful not to add oil above the upper limit of the oil level gauge.

■ Replacement of oil filter cartridge

[D1803-CR-E4, D1803-CR-TE4, V2403-CR-E4, V2403-CR-TE4]



CAUTION

To avoid personal injury:

- Be sure to stop the engine before changing the oil filter cartridge.
- Allow engine to cool down sufficiently, oil can be hot and cause burns.

1. Replace the oil filter cartridge. Oil filter cartridge should be replaced after the initial 50 hours of operation and every 400 hours thereafter.
2. Remove the old oil filter cartridge with a filter wrench.
3. Apply a film of oil to the gasket for the new cartridge.
4. Screw in the cartridge by hand. When the gasket contacts the seal surface, tighten the cartridge enough by hand. Because, if you tighten the cartridge with a wrench, it will be tightened too much.

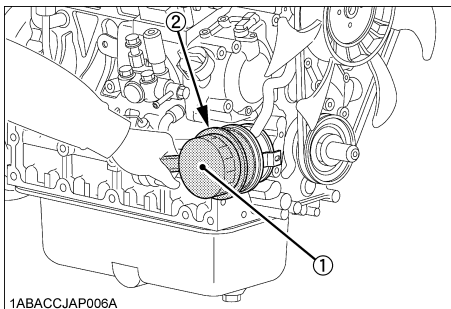

1ABACCJAP006A

- (1) Oil filter cartridge
- (2) Remove with a filter wrench (Tighten with your hand)

5. After the new cartridge has been replaced, the engine oil level normally decreases a little. Thus, run the engine for a while and check for oil leaks through the seal before checking the engine oil level. Add oil if necessary.

NOTE :

- Wipe off any oil sticking to the machine completely.

EVERY 500 SERVICE HOURS

■ Changing of engine oil

[V2607-CR-E4, V2607-CR-TE4, V3307-CR-TE4, V3800-CR-TE4, V3800-CR-TIE4]



CAUTION

To avoid personal injury:

- Be sure to stop the engine before draining engine oil.
 - When draining engine oil, place some container underneath the engine and dispose it according to local regulations.
 - Do not drain oil after running the engine. Allow engine to cool down sufficiently.
1. Change oil after the initial 50 hours of operation and every 500 hours thereafter. When the annual operating hours are below 500, replace the oil every year.
 2. Remove the drain plug at the bottom of the engine, and drain all the old oil. Drain oil will drain easier when the oil is warm.

[V2607-CR-E4, V2607-CR-TE4, V3307-CR-TE4]

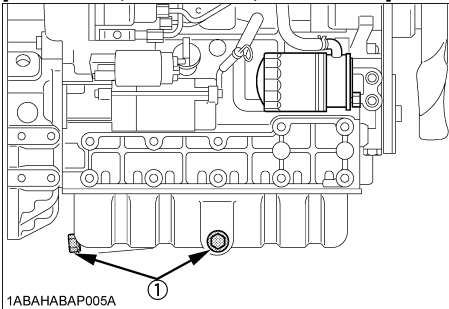

1ABAHABAP005A
(1) Oil drain plug

[V3800-CR-TE4, V3800-CR-TIE4]

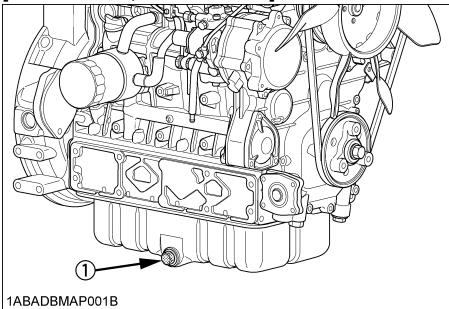

1ABADBMAP001B
(1) Oil drain plug

3. When letting out the oil, remove the filler plug too. With the filler plug still in place, it would be difficult to discharge the oil completely.
4. Add new engine oil up to the upper limit of the oil level gauge. Be careful not to add oil above the upper limit of the oil level gauge.

■ Replacement of oil filter cartridge

[V2607-CR-E4, V2607-CR-TE4, V3307-CR-TE4, V3800-CR-TE4, V3800-CR-TIE4]



CAUTION

To avoid personal injury:

- Be sure to stop the engine before changing the oil filter cartridge.
 - Allow engine to cool down sufficiently, oil can be hot and cause burns.
1. Replace the oil filter cartridge. Oil filter cartridge should be replaced after the initial 50 hours of operation and every 500 hours thereafter.
 2. Remove the old oil filter cartridge with a filter wrench.
 3. Apply a film of oil to the gasket for the new cartridge.
 4. Screw in the cartridge by hand. When the gasket contacts the seal surface, tighten the cartridge enough by hand. Because, if you tighten the cartridge with a wrench, it will be tightened too much.

[V2607-CR-E4, V2607-CR-TE4, V3307-CR-TE4]

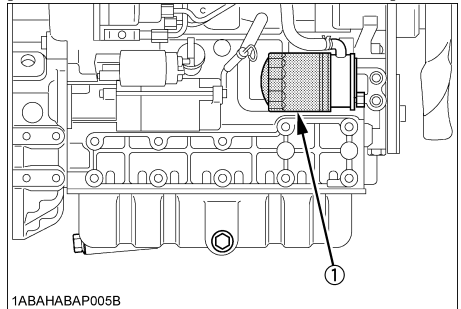

1ABAHABAP005B
(1) Oil filter cartridge

[V3800-CR-TE4, V3800-CR-TIE4]

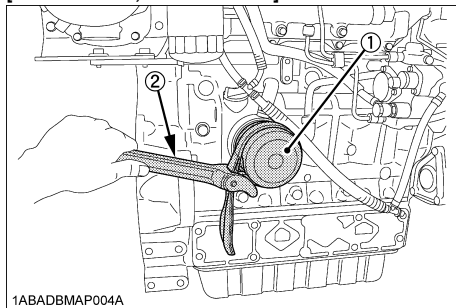

- (1) Oil filter cartridge
 (2) Remove with a filter wrench (Tighten with your hand)

5. After the new cartridge has been replaced, the engine oil level normally decreases a little. Thus, run the engine for a while and check for oil leaks through the seal before checking the engine oil level. Add oil if necessary.

NOTE :

- Wipe off any oil sticking to the machine completely.

Replacement of fuel filter cartridge

1. Replace the fuel filter cartridge with a new one every 500 operating hours.
2. Apply fuel oil thinly over the gasket and tighten the cartridge into position by hand-tightening only.
3. Finally, vent the air.

IMPORTANT :

- Replace the fuel filter cartridge periodically to prevent wear of the supply pump or the injector, due to dirt in the fuel.

NOTE :

- The fuel filter cartridge and water separator should be replaced earlier according to the fuel classification in use.

Cleaning of water separator (Type 1)

(See "Draining of water separator" in "EVERY 50 SERVICE HOURS" in "REGULAR CHECKS AND MAINTENANCE WORK" section.)

Removal of sediment in fuel tank

Consult your local KUBOTA Dealer for this service.

Cleaning of water jacket (radiator interior)

Consult your local KUBOTA Dealer for this service.

Replacement of fan belt

Consult your local KUBOTA Dealer for this service.

(See "Adjustment of fan belt tension" in "EVERY 250 SERVICE HOURS" in "REGULAR CHECKS AND MAINTENANCE WORK" section.)

EVERY 500 SERVICE HOURS OR 1 YEAR**Replacement of water separator filter (Type 2)**

1. Replace the water separator filter with a new one every 500 hours or 1 year.
2. Remove the old water separator filter with a filter wrench.
3. Apply a film of oil to the gasket for the new water separator filter.
4. Screw in the water separator filter by hand. Because, if you tighten the water separator filter with a wrench, it will be tightened too much.

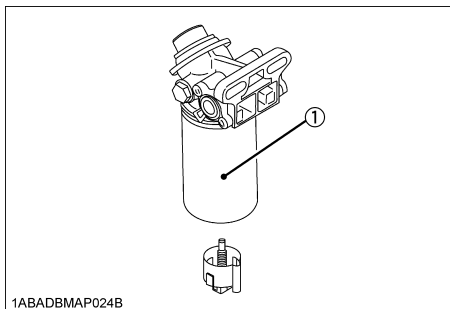

1ABADBMAP024B

- (1) Water separator filter

IMPORTANT :

- Replace the water separator filter periodically to prevent wear of the supply pump or the injector, due to dirt in the fuel.

EVERY 1000 SERVICE HOURS**Checking of valve clearance**

Consult your local KUBOTA Dealer for this service.

EVERY 1500 SERVICE HOURS**Checking of injector tip**

Consult your local KUBOTA Dealer for this service.

Checking of EGR cooler

Consult your local KUBOTA Dealer for this service.

■ Changing of oil separator element



CAUTION

To avoid personal injury:

- Be sure to stop the engine before changing the oil separator element.

1. Remove the cover and take out the oil separator element and gasket. Then wipe oil and grease off the zone in question.
2. Fit a new oil separator element and gasket into position.

[D1803-CR-E4, D1803-CR-TE4,
V2403-CR-E4, V2403-CR-TE4]

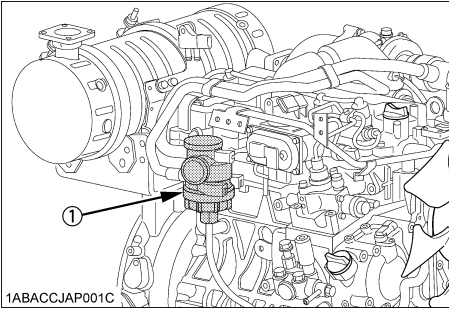

1ABACCJAP001C

(1) Oil separator

[V2607-CR-E4, V2607-CR-TE4, V3307-CR-TE4]

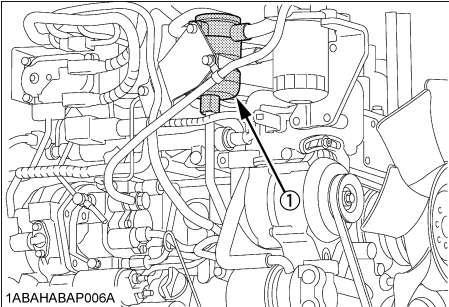

1ABAHABAP006A

(1) Oil separator

[V3800-CR-TE4, V3800-CR-TIE4]

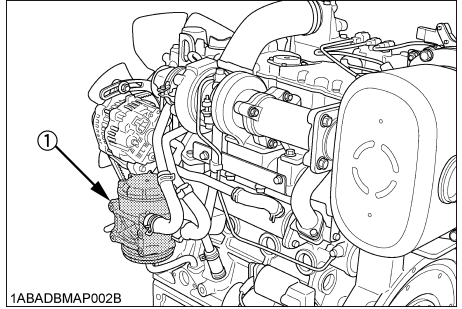

1ABADBMAP002B

(1) Oil separator

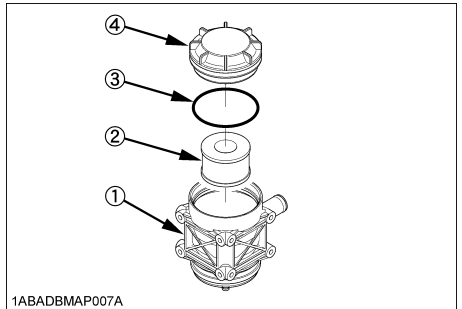

1ABADBMAP007A

- (1) Body
- (2) Oil separator element
- (3) Gasket
- (4) Cover

■ Checking of PCV valve (Positive Crankcase Ventilation valve)

[V3800-CR-TE4, V3800-CR-TIE4]

Consult your local KUBOTA Dealer for this service.

EVERY 3000 SERVICE HOURS

■ Checking of turbo-charger

Consult your local KUBOTA Dealer for this service.

■ Cleaning of DPF

Consult your local KUBOTA Dealer for this service.

◆ Removal of ash

The longer the DPF runs, the more ash (burnt residue) is collected in the filter. Too much ash build-up adversely affects the DPF performance. Ask your local KUBOTA Dealer to clean up the filter every 3000 operating hours.

◆ White exhaust from the exhaust pipe at a start-up or speed-up

Because of the DPF characteristics, the following conditions may be found. They are not anything unusual, however. (They are caused by moisture.)

- (1) White exhaust may come out of the muffler at a start-up or speed-up after a long-hour idling.
- (2) White exhaust and/or water may also come out in cold season or just after a start-up.

◆ DPF regeneration

- The DPF is designed to burn (DPF-regenerate) trapped particulate matters in an automatic way. Depending on operating conditions, however, the regeneration may fail to go through and these matters may build up in the DPF. If the DPF warning lamp lights up and the manual DPF regenerating switch indicator starts blinking, turn on the manual DPF regenerating switch.
- Manual DPF regeneration may be required depending on the engine operating situation. The manual regenerating procedure is referred to in the operator's manual of the connected machine.
- During manual DPF regeneration, the exhaust gas becomes hotter than usual and its quantity increases. Check to see if there is nothing flammable around and the place is well ventilated. Refer to the operator's manual of the connected machine.
- When the interval of DPF regeneration has become 5 hours or shorter routinely, change the oil for new one. If this condition continues even after an oil change, consult your local KUBOTA Dealer.

■ Checking of EGR System

Consult your local KUBOTA Dealer for this service.

ANNUAL SERVICING

■ Replacement of air cleaner element

Consult your local KUBOTA Dealer for this service. (See "Cleaning of air cleaner element" in "EVERY 250 SERVICE HOURS" in "REGULAR CHECKS AND MAINTENANCE WORK" section.)

■ Checking of DPF related piping

Consult your local KUBOTA Dealer for this service.

■ Checking of EGR piping

Consult your local KUBOTA Dealer for this service.

■ Checking of intake air line

Visually check for cracks, gas leak and anything else unusual.

Check to see if the lock bolts and nuts are tight enough.

■ Checking of exhaust manifold for cracks or gas leak and for looseness or damage

Visually check for cracks, damages, gas leak and anything else unusual.

Check to see if the lock bolts and nuts are tight enough.

BIENNIAL SERVICING

■ Replacement of oil separator related rubber piping

Consult your local KUBOTA Dealer for this service.

■ Replacement of DPF related rubber piping

Consult your local KUBOTA Dealer for this service.

■ Replacement of intake air line and suction air pressure takeout rubber piping

Consult your local KUBOTA Dealer for this service.

■ Replacement of boost sensor pressure rubber piping

Consult your local KUBOTA Dealer for this service.

■ Replacement of EGR cooler rubber piping

Consult your local KUBOTA Dealer for this service.

■ Replacement of water rubber piping

Consult your local KUBOTA Dealer for this service.

■ Replacement of lubricant rubber piping

Consult your local KUBOTA Dealer for this service.

■ Changing of radiator coolant (L.L.C.)

1. To drain coolant, always open both drain cocks and simultaneously open the radiator cap as well. With the radiator cap kept closed, a complete drain of water is impossible.
2. Remove the overflow pipe of the radiator pressure cap to drain the recovery tank.
3. Prescribed coolant volume (U.S.gallons)

Models	Quantity
D1803-CR-E4 D1803-CR-TE4	5.8 L (1.53 U.S.gals.)
V2403-CR-E4 V2403-CR-TE4	8.4 L (2.22 U.S.gals.)
V2607-CR-E4 V2607-CR-TE4	6.0 L (1.32 U.S.gals.)
V3307-CR-TE4	6.3 L (1.67 U.S.gals.)
V3800-CR-TE4 V3800-CR-TIE4	9.0 L (2.38 U.S.gals.)

NOTE :

- Coolant quantities shown are for standard radiators.
4. An improperly tightened radiator cap or a gap between the cap and the seat quickens loss of coolant.
 5. Coolant (Radiator cleaner and anti-freeze)

Season	Coolant
All seasons	Pure water and anti-freeze (See "Anti-freeze" in "DAILY CHECKS" in "MAINTENANCE" section.)

■ Remedies for quick decrease of coolant

1. Check any dust and dirt between the radiator fins and tube. If any, remove them from the fins and the tube.
2. Check the tightness of the fan belt. If loose, tighten it securely.
3. Check the internal blockage in the radiator hose. If scale forms in the hose, clean with the scale inhibitor or its equivalent.

■ Replacement of radiator hoses and clamp bands

Consult your local KUBOTA Dealer for this service.
(See "Checking of radiator hoses and clamp bands" in "EVERY 250 SERVICE HOURS" in "REGULAR CHECKS AND MAINTENANCE WORK" section.)

■ Replacement of fuel pipes and clamp bands

Consult your local KUBOTA Dealer for this service.
(See "Checking of fuel pipes and clamp bands" in "EVERY 50 SERVICE HOURS" in "REGULAR CHECKS AND MAINTENANCE WORK" section.)

■ Replacement of intake air line

Consult your local KUBOTA Dealer for this service.

■ Replacement of fan belt

Consult your local KUBOTA Dealer for this service.
(See "Adjustment of fan belt tension" in "EVERY 250 SERVICE HOURS" in "REGULAR CHECKS AND MAINTENANCE WORK" section.)

SERVICE AS REQUIRED

■ Draining of water separator (Type 2)

If water or impurities collect in the water separator, the indicator in the monitor will light up. For more details, refer to the operator's manual for the equipment.

If this should happen during operation, drain from the switch assy.

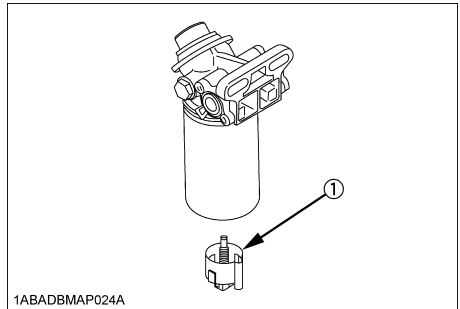

1ABADBMAP024A

(1) Switch assy

IMPORTANT :

- Be sure to air-bleed the fuel system before getting the engine restarted.

CARRIAGE AND STORAGE

CARRIAGE



CAUTION

To avoid personal injury:

- Fix the engine securely not to fall during operation.
- Do not stand near or under the engine while carrying it.
- The engine is heavy. In handling it, be very alert not to get your hands and body caught in.

1. Use carrier such as a crane when moving the engine to avoid bodily injury. Support the engine securely to avoid injury or damage.
2. When lifting the engine, put the hook securely to metal fittings attached to the engine. Use strong hook and fittings enough to hang the engine.

NOTE :

- In the above step, do not hook the lifting sling to the DPF.

STORAGE



CAUTION

To avoid personal injury:

- Do not clean the machine with engine running.
- To avoid the danger of exhaust fume poisoning, do not operate the engine in a closed building without proper ventilation.
- When storing the engine just after running, let the engine cool off.

Before storing the engine for more than a few months, remove any dirt on the machine, and:

1. Drain the coolant in the radiator. Open the cock at the bottom of the radiator, and remove the pressure cap to drain water completely. Leave the cock open. Hang a note written "No water" on the pressure cap. Since water may freeze when the temperature drops below 0° C (32° F), it is very important that no water is left in the machine.

NOTE :

- When using anti-freeze, it is not necessary to take step (1) above.
2. Remove dirty engine oil, fill with new oil and run the engine for about 5 minutes to let the oil penetrate to all the parts.
 3. Check all the bolts and nuts, and tighten if necessary.
 4. Remove the battery from the engine, adjust the electrolyte level, and recharge it. Store the battery in a dry and dark place.
 5. When the engine is not used for a long period of time, run it for about 5 minutes under no load every 2 to 3 months to keep it free from rust. If the engine is stored without any running, moisture in the air may condense into dew over the sliding parts of the engine, resulting in rust there.
 6. If you forget to run the engine for longer than 5 to 6 months, apply enough engine oil to the valve guide and valve stem seal and make sure the valve works smoothly before starting the engine.
 7. Store the engine in a flat place and remove the key from engine.
 8. Do not store the engine in a place where has flammable materials such as dry grass or straw.
 9. When covering the engine for storage, let engine and muffler cool off completely.
 10. Operate the engine after checking and repairing damaged wirings or pipes, and clearing flammable materials carried by mouse.

TROUBLESHOOTING

If the engine does not function properly, use the following chart to identify and correct the cause.

■ When it is difficult to start the engine

Cause	Countermeasures
Fuel is thick and doesn't flow.	<ul style="list-style-type: none"> * Check the fuel tank, and remove water, dirt and other impurities. * Check the fuel filter cartridge and replace it if necessary.
Engine oil becomes thick in cold weather and engine cranks slow.	<ul style="list-style-type: none"> * Use oils of different viscosities, depending on ambient temperatures. (Use 10W-30 in winter season.)
Battery is discharged and the engine will not crank.	<ul style="list-style-type: none"> * Charge the battery.

■ When output is insufficient

Cause	Countermeasures
Fuel is insufficient.	<ul style="list-style-type: none"> * Refuel. * Check the fuel system. (Bleed the fuel system if necessary.)
Overheating of moving parts	<ul style="list-style-type: none"> * Consult your KUBOTA Dealer.
Air cleaner is dirty.	<ul style="list-style-type: none"> * Clean the element.
The output is limited because of a trouble.	<ul style="list-style-type: none"> * Check the engine warning lamp. (If a trouble occurs, it means that the ECU might be in the output limiting mode.)

■ When engine suddenly stops

Cause	Countermeasures
Lack of fuel	<ul style="list-style-type: none"> * Refuel. * Check the fuel system. (Bleed the fuel system if necessary.)
Overheating of moving parts	<ul style="list-style-type: none"> * Consult your KUBOTA Dealer.
Air cleaner is dirty.	<ul style="list-style-type: none"> * Clean the element.
Forced stop due to a trouble	<ul style="list-style-type: none"> * Check the engine warning lamp. (If a serious trouble occurs, it means that the ECU might have forced the engine to a stop.)

NOTE :

- If the cause of trouble can not be found, contact your KUBOTA Dealer.

IMPORTANT :

- If any of the sensors of common-rail engine malfunctions, the engine output and rotating speed drops during the run. In such case, contact your KUBOTA Dealer for repair.

■ When engine must be stopped immediately

Cause	Countermeasures
Engine revolution suddenly decreases or increases.	* Check the adjustments and the fuel system.
Unusual sound is heard.	* Check all moving parts carefully.
Color of exhaust suddenly turns dark.	* Check the DPF itself.
Oil lamp lights up during operation.	* Check the lubricating system. * Check to see if the engine bearing clearances are within factory specs. * Check the function of the relieve valve in the lubricating system. * Check pressure switch. * Check filter base gasket.
Engine warning lamp lights up.	* Consult your KUBOTA Dealer.
DPF service lamps light up.	* Consult your KUBOTA Dealer.

■ When engine overheats

Cause	Countermeasures
Engine oil insufficient	* Check oil level. Replenish oil as required.
Fan belt broken or elongated	* Change belt or adjust belt tension.
Coolant insufficient	* Replenish coolant.
Excessive concentration of antifreeze	* Add water only or change to coolant with the specified mixing ratio.
Radiator net or radiator fin clogged with dust	* Clean net or fin carefully.
Inside of radiator or coolant flow route corroded	* Clean or replace radiator and parts.
Fan or radiator or radiator cap defective	* Replace defective parts.
Thermostat defective	* Check thermostat and replace if necessary.
Temperature gauge or sensor defective	* Check temperature with thermometer and replace if necessary.
Overload running	* Reduce load.
Head gasket defective or water leakage	* Replace parts.

SPECIFICATIONS

Model	D1803-CR-E4	D1803-CR-TE4	
Type	Vertical, water-cooled, 4-cycle diesel engine		
Number of cylinders	3		
Bore and stroke mm (in.)	87 x 102.4 (3.43 x 4.04)		
Total displacement L (cu.in.)	1.826 (111.43)		
Combustion type	Direct injection type		
Output: Gross Intermittent	kW / min ⁻¹ (rpm) (PS / min ⁻¹ (rpm))	28.0 / 2700 (38.1 / 2700)	37.0 / 2700 (50.3 / 2700)
Max. torque / Rotating speed	N-m / min ⁻¹ (rpm) (kg-m / min ⁻¹ (rpm))	115.8 / 1600 (11.8 / 1600)	150.5 / 1600 (15.3 / 1600)
Maximum bare speed min ⁻¹ (rpm)	2900		
Minimum bare idling speed min ⁻¹ (rpm)	775 to 825		
Order of firing	1-2-3		
Direction of rotation	Counter-clockwise (viewed from flywheel side)		
Compression ratio	18.1		
Fuel	Diesel Fuel No.2-DULS		
Lubricant (API classification)	CJ-4 or CK-4		
Dimension (length x width x height)	mm (in.)	744 x 507 x 721 (29.2 x 20.0 x 28.3)	744 x 513 x 735 (29.2 x 20.2 x 28.9)
Dry weight kg (lbs.)	185 (407)		196 (432)
Starting system	Cell starter		
Starting motor	12V, 1.4 kW		
Charging generator	12V, 480 W		
Recommended battery capacity	12V, 88 AH		

NOTE :

- Specifications are subject to change without notice.

Model		V2403-CR-E4	V2403-CR-TE4
Type		Vertical, water-cooled, 4-cycle diesel engine	
Number of cylinders		4	
Bore and stroke mm (in.)		87 x 102.4 (3.43 x 4.04)	
Total displacement L (cu.in.)		2.434 (148.53)	
Combustion type		Direct injection type	
Output:	kW / min ⁻¹ (rpm)	37.4 / 2700	48.6 / 2700
Gross Intermittent	(PS / min ⁻¹ (rpm))	(50.8 / 2700)	(66.1 / 2700)
Max. torque / Rotating speed	N-m / min ⁻¹ (rpm)	159.8 / 1600	198.5 / 1600
	(kg-m / min ⁻¹ (rpm))	(16.3 / 1600)	(20.2 / 1600)
Maximum bare speed	min ⁻¹ (rpm)	2900	
Minimum bare idling speed	min ⁻¹ (rpm)	775 to 825	
Order of firing		1-3-4-2	
Direction of rotation		Counter-clockwise (viewed from flywheel side)	
Compression ratio		18.1	
Fuel		Diesel Fuel No.2-DULS	
Lubricant (API classification)		CJ-4 or CK-4	
Dimension	mm (in.)	869 x 517 x 721 (34.2 x 20.4 x 28.3)	869 x 517 x 735 (34.2 x 20.4 x 28.9)
Dry weight	kg (lbs.)	221 (488)	233 (513)
Starting system		Cell starter	
Starting motor		12V, 2.0 kW	
Charging generator		12V, 480 W	
Recommended battery capacity		92 Ah	

NOTE :

- Specifications are subject to change without notice.

Model	V2607-CR-E4	V2607-CR-TE4	V3307-CR-TE4	
Type	Vertical, water-cooled, 4-cycle diesel engine			
Number of cylinders	4			
Bore and stroke mm (in.)	87 x 110 (3.43 x 4.33)		94 x 120 (3.70 x 4.72)	
Total displacement L (cu.in.)	2.615 (160.04)		3.331 (203.27)	
Combustion type	Direct injection type			
Output: Gross Intermittent	kW / min ⁻¹ (rpm) (PS / min ⁻¹ (rpm))	42.0 / 2700 (57.1 / 2700)	53.0 / 2700 (72.1 / 2700)	55.4 / 2600 (75.3 / 2600)
Max. torque / Rotating speed	N-m / min ⁻¹ (rpm) (kg-m / min ⁻¹ (rpm))	174.1 / 1600 (17.7 / 1600)	225 / 1600 (22.9 / 1600)	265 / 1500 (27.0 / 1500)
Maximum bare speed min ⁻¹ (rpm)	2900		2800	
Minimum bare idling speed min ⁻¹ (rpm)	775 to 825			
Order of firing	1-3-4-2			
Direction of rotation	Counter-clockwise (viewed from flywheel side)			
Compression ratio	18.0	16.8	17.5	
Fuel	Diesel Fuel No.2-DULS			
Lubricant (API classification)	CJ-4 or CK-4			
Dimension (length x width x height) mm (in.)	875 x 542 x 723 (34.4 x 21.4 x 28.4)		900 x 592 x 753 (35.4 x 23.3 x 29.6)	
Dry weight kg (lbs.)	267 (589)	272 (599)	305 (672)	
Starting system	Cell starter			
Starting motor	12V, 2.5 kW		12V, 3.0 kW	
Charging generator	12V, 720 W			
Recommended battery capacity	12V, 92 AH		12V, 108 AH	

NOTE :

- Specifications are subject to change without notice.

Model		V3800-CR-TE4	V3800-CR-TIE4
Type		Vertical, water-cooled, 4-cycle diesel engine	
Number of cylinders		4	
Bore and stroke mm (in.)		100 x 120 (3.93 x 4.72)	
Total displacement L (cu.in.)		3.769 (229.41)	
Combustion type		Direct injection type	
Output:	kW / min ⁻¹ (rpm)	74.5 / 2600	86.3 / 2600
Gross Intermittent	(PS / min ⁻¹ (rpm))	(101.3 / 2600)	(117.4 / 2600)
Max. torque / Rotating speed	N-m / min ⁻¹ (rpm)	335 / 1500	375 / 1500
	(kg-m / min ⁻¹ (rpm))	(34.2 / 1500)	(38.2 / 1500)
Maximum bare speed	min ⁻¹ (rpm)	2800	
Minimum bare idling speed	min ⁻¹ (rpm)	800	
Order of firing		1-3-4-2	
Direction of rotation		Counter-clockwise (viewed from flywheel side)	
Compression ratio		17.5	
Fuel		Diesel Fuel No.2-DULS	
Lubricant (API classification)		CJ-4 or CK-4	
Dimension (length x width x height)		835 x 580 x 835 (32.9 x 22.8 x 32.9)	
Dry weight	kg (lbs.)	325 (716.5)	421 (928.1)
Starting system		Cell starter	
Starting motor		12V, 3.0 kW	
Charging generator		12V, 540 W	
Recommended battery capacity		12V, 136 AH	

NOTE :

- Specifications are subject to change without notice.